



# **EASTERN UNIVERSITY, SRI LANKA**

## **BIDDING DOCUMENT**

**FOR**

**Construction of Livestock Shed for Faculty of Agriculture at  
Technology Premises at Eastern University, Sri Lanka**

**Issued to** : .....

**Issued by** : .....

**Date** : .....

**Bid No.** : .....

**Non-refundable Fee Receipt No. & Date:** .....

## CONTENTS

<u>NO</u>		<u>PAGE</u>
INVITATION FOR BIDS	-	03
<b>VOLUME I</b>		
SECTION 1	INSTRUCTIONS TO BIDDERS	06
SECTION 2	STANDARD FORMS	09
SECTION 3	CONDITIONS OF CONTRACT	16
<b>VOLUME II</b>		
SECTION 4	FORM OF BID AND QUALIFICATION INFORMATION	19
SECTION 5	BIDDING DATA AND CONTRACT DATA	24
SECTION 6	SPECIFICATIONS	35
SECTION 7	BILL OF QUANTITIES	37
SECTION 8	DRAWINGS	49
SECTION 9	STANDARD FORM [BID]	64
SECTION 10	VAT FORM	66
SECTION 11	CHECK LIST	68



**Eastern University, Sri Lanka**  
**Invitation for Bids (IFB)**  
**National Comparative Bids (NCB)**

**Rehabilitation and Improvement of Building and other Structures at Eastern University, Sri Lanka**

The Chairman, Department Procurement Committee, on behalf of the Eastern University, Sri Lanka will receive sealed bids from interested eligible and qualified bidders for the works mentioned in the table given below and receiving will be closed at 10.30 a.m. on 27/11/2020. Bidding documents shall be obtained from Senior Assistant Registrar (Capital Works & Planning) up to 26/11/2020 or downloaded from the website of the EUSL. The non-refundable tender fee as mentioned in table below shall be credited to the Account No: 227100140000024 in the Peoples Bank in favor of "Bursar, Eastern University, Sri Lanka" or online at <http://pay.esn.ac.lk/>.

S. No	Name of Work	Estimated Cost Excl. VAT (Rs)	Required ICTAD/CIDA Valid Grade and the Specialty	Bid validity period	Bid Security (Rs)	Bid Security valid up to	Non-refundable tender fee (Rs)
1.0	Construction of Livestock Shed for Faculty of Agriculture Technology Premises, Eastern University, Sri Lanka.	10,684,473.40	C6 and C5 Building	77 days	150,000.00	12/03/2021	3,500.00

1. Bidding will be conducted through National Competitive Bidding Method (NCB). Since the Total Cost Estimate of this procurement is below Rs. 50 Mn., regional preference and CIDA grade preference shall apply as stipulated in Public Finance Circular No. 04/2016 (ii).
2. The bidders shall also register themselves with the Registrar of Public Contracts, Sri Lanka in terms of the Public Contract Act No. 03 of 1987. The Original Certificate of Registration (PCA 03) shall be submitted with the bid. Contract shall not be awarded to any bidder unless such bidder had submitted the PCA 03 certificate.

3. Bids shall be accompanied by a Bid Security which shall be;
  - in the format included in the Bidding document
  - in favour of **Vice Chancellor, Eastern University, Sri Lanka**
  - amount and validity period as mentioned above
  - issued by a commercial bank operating in Sri Lanka and approved by the Central Bank of Sri Lanka or Construction Guarantee Fund
4. Sealed Bids shall be delivered to the address given below. The bids received after the closing time and date will be rejected.

Bids to be delivered to:

**The Chairman  
Department Procurement Committee  
Eastern University, Sri Lanka  
Vantharumoolai, Chenkalady**

5. Bids will be opened immediately after the closing time at the above address.
6. Bidders or their authorized representatives are requested to be present at the opening of Bids.
7. Interested bidders may obtain further information from Senior Assistant Registrar (CW&P) on 065 2240589 (dr\_capitalworks@esn.ac.lk) and Works Engineer on 065 2240582 (worksengineer@esn.ac.lk) of Eastern University, Sri Lanka at Chenkalady during any working days from 9.00 hrs to 14.00 hrs.

**The Chairman  
Department Procurement Committee  
Eastern University, Sri Lanka  
Vantharumoolai  
Chenkalady.  
13/11/2020**

---

---

# VOLUME I

---

---

## CONTENTS

<u>SECTION</u>	<u>DESCRIPTION</u>	<u>PAGE NO</u>
SECTION 1	INSTRUCTIONS TO BIDDERS	06
SECTION 2	STANDARD FORMS	09
SECTION 3	CONDITIONS OF CONTRACT	16

**SECTION 1**  
**INSTRUCTIONS TO BIDDERS**

# SECTION 1

## INSTRUCTIONS TO BIDDERS

1. The Instructions to the Bidders for this work are contained in Section 01 of the Standard Bidding Document, “Procurement of Works”, ICTAD/CIDA Publication No. ICTAD/SBD/01, Second Edition – January 2007 and Addendum 1 and 2 published on October 2009 and February 2011 respectively. The Bidder may purchase this document from Institute for Construction Training And Development, No. 123, Wijerama Mawatha, “Sawsiripaya”, Colombo-07.

<p><i>Note:</i></p> <ol style="list-style-type: none"><li>1. <b>Instructions to Bidders shall be read in conjunction with Section 05 Bidding Data– Volume II.</b></li><li>2. <b>Instruction to Bidders will not be a part of the Contract and will cease to have effect once the Contract is signed.</b></li></ol>
--





# **SECTION 2**

## **STANDARD FORMS [CONTRACT]**

- 1. FORM OF LETTER OF ACCEPTANCE**
- 2. AGREEMENT**
- 3. FORM OF PERFORMANCE SECURITY**
- 4. FORM OF ADVANCE PAYMENT SECURITY**
- 5. FORM OF RETENTION MONEY GUARANTEE**

## *Form of Letter of Acceptance*

.....[date]

[LETTER HEADING PAPER OF THE PROCURING ENTITY]

To: ----- [name and address of the Contractor] -----

*Name of the project and Contract No.*

This is to notify you that your bid dated ----- [insert date] for the construction and remedying defects of the ----- [name of the Contract and identification number] for the Contract price of -----[name of currency]----- [amount in figures and words] as corrected in accordance with Instructions to Bidders and/ or modified by a Memorandum of Understanding, is hereby accepted.

You are hereby instructed to proceed with the execution of the said Works in accordance with the Contract documents.

The Commencement Date shall be: ..... (fill the date as per Clause 6.1 of Conditions of Contract).

The amount of Performance Security is : ..... (fill the amount as per Clause 4.4 of Conditions of Contract).

The Performance Security shall be submitted on or before ..... (fill the date as per Clause 4.4 of Conditions of Contract).

Authorized Signature:.....

Name and title of Signatory: .....

Name of Agency: .....

## ARTICLE OF AGREEMENT

This ARTICLES of Agreement, made the ..... day of ..... -.....-2012 between ..... holding the office of the Vice Chancellor of the Eastern University, Sri Lanka in the Government of the Democratic Socialist Republic of Sri Lanka (hereinafter called the "the Employer") for himself and his successors in the said office for the time being, acting for and on behalf of the DEMOCRATIC SOCIALIST REPUBLIC OF SRI LANKA (hereinafter sometimes referred to as the Republic of Sri Lanka) of the one part and ..... .. trading under the name, firm and style of **Messrs.** ..... a Company duly incorporated and having its registered office at .....(hereinafter designated "the Contractor" which expressions shall include his or their heirs, executors, administrators and legal representatives or where the context so admits, include its successors and permitted assigns) of the other part.

WHEREAS the Employer is desirous that the Contractor execute.....(hereinafter called "the Works")and the Employer has accepted the Bid by the Contractor for the execution and completion of such Works and the remedying of any defects therein.

NOW THIS AGREEMENT WITNESSETH as follows:

1. In this Agreement, words and expressions shall have the same meanings as are respectively assigned to them in the Conditions of Contract hereinafter referred to, and they shall be deemed to form and be read and construed as part of this Agreement.
2. In consideration of the payments to be made by the Employer to the Contractor as hereinafter mentioned, the Contractor hereby covenants with the Employer to execute and complete the Works and remedy any defects therein in conformity in all respects with the provisions of the Contract.

3. The Employer hereby covenants to pay the Contractor in consideration of the execution and completion of the Works and the remedying of defects wherein the Contract Price or such other sum as may become payable under the provisions of the Contract at the times and in the manner prescribed by the Contract.

IN WITNESS whereof the parties thereto have caused this Agreement to be executed the day and year aforementioned in accordance with laws of Sri Lanka.

.....

**Signature of the Vice Chancellor, Eastern University, Sri Lanka**

WITNESSES:

1. Signature:.....

2. Signature:.....

Designation:.....

Designation:.....

.....

**Signature of the Contractor/Director of the Company**

Name : .....

NIC No.....

**Common Seal**

WITNESSES:

1. Signature.....

2. Signature.....

NIC No.....

NIC No.....

Name & Address.....

Name & Address.....

.....

.....

.....

.....

**Form of Performance Security**  
**(Unconditional)**

**Issuing Agency:** .....  
*[Issuing Agency Name and Address of Issuing Branch or Office]*

**Beneficiary:** Vice Chancellor,  
Eastern University, Sri Lanka

**Date:** .....

**PERFORMANCE GUARANTEE No:** .....

We have been informed that ..... *[name of the Company]* (hereinafter called "the Contractor") has entered into Contract No. .... *[reference number of the contract]* with you, in the year ....., for the..... *[name of the Contract]* (hereinafter called "the Contract");

Furthermore, we understand that, according to the conditions of the Contract, a performance guarantee is required.

At the request of the Contractor, we ..... *[name of Agency]* hereby irrevocably undertake to pay you any sum or sums not exceeding in total an amount of ..... *[amount in words]* (.....) *[amount in figures]*, upon receipt by us of your first demand in writing accompanied by a written statement stating that the Contractor is in breach of its obligation(s) under the Contract, without your needing to prove or to show grounds for your demand or the sum specified therein.

This guarantee shall expire, no later than the ..... day of ..... 20..... *[insert date, 28 days beyond the intended completion Date]* and any demand for payment under it must be received by us at this office on or before that date.

.....  
*[signature(s)]*

## *Form of Advance Payment Security*

**Issuing Agency:** ..... [Name and Address of Agency, and Address of Issuing Branch or Office]

**Beneficiary:** Vice Chancellor,  
Eastern University, Sri Lanka

**Date:** .....

**ADVANCE PAYMENT GUARANTEE No:** .....

We have been informed that ..... [name of Contractor] (hereinafter called "the Contractor") has entered into Contract No. .... [reference number of the contract] with you, in the year ....., for the..... [name of the contract] (hereinafter called "the Contract");

Furthermore, we understand that, according to the conditions of the Contract, an advance payment in the sum ..... [amount in words] (.....) [amount in figures] is to be made against an advance payment guarantee.

At the request of the Contractor, we ..... [name of Issuing agency] hereby irrevocably undertake to pay you any sum or sums not exceeding in total an amount of ..... [amount in words] (.....) [amount in figures], upon receipt by us of your first demand in writing accompanied by a written statement stating that the Contractor is in breach of its obligation in repayment of the Advance payment under the Contract

The maximum amount of this guarantee shall be progressively reduced by the amount of the advance payment repaid by the Contractor.

This guarantee shall expire on ..... [insert date, 28 days beyond the Intended Completion Date]

Consequently, any demand for payment under this guarantee must be received by us at this office on or before that date.

.....  
[signature(s)]

## *Form of Retention Money Guarantee*

**Issuing Agency:** .....

-- [Issuing Agency's Name and Address of Issuing Branch or Office]

**Beneficiary:** Vice Chancellor,  
Eastern University, Sri Lanka

**Date:** .....

**RETENTION MONEY GUARANTEE No:** .....

We have been informed that ..... [name of Contractor] (hereinafter called "the Contractor") has entered into Contract No. .... [reference number of the contract] with you, in the year ....., for the execution of ..... [name of the Contract and brief descriptions of Works] (hereinafter called "the Contract");

Furthermore, we understand that, according to the conditions of the Contract, when the works have been taken over and the first half of the Retention Money has been certified for the payment, payment of the second half of the Retention Money may be made against a Retention Money guarantee.

At the request of the Contractor, we ..... [name of Agency] hereby irrevocably undertake to pay you any sum or sums not exceeding in total an amount of ..... [amount in words] (.....) [amount in figures], upon receipt by us of your first demand in writing accompanied by a written statement stating that the Contractor is in breach of its obligation under the Contract, because the contractor has not attended to the defects in accordance with the Contract.

This guarantee shall expire, at the latest, ..... [insert date, 28 Days after the end of the Defects Liability Period] Consequently, any demand for payment under this guarantee must be received by us at this office on or before that date.

.....  
[signature(s)]

**SECTION 3**  
**CONDITIONS OF CONTRACT**



## CONDITIONS OF CONTRACT

### PART I - GENERAL CONDITIONS OF CONTRACT

1. The General Conditions for this work are contained in Section 03 of the Standard Bidding Document, "Procurement of Works", ICTAD Publication No. ICTAD/SBD/01, Second Edition - January 2007 and Addendum 1 and 2 published on October 2009 and February 2011 responsively. The Bidder may purchase this document from Construction Training And Development, No. 123, Wijerama Mawatha, "Sawsiripaya",Colombo-07.

<p><b><i>Note:</i> Conditions of Contract shall be read in conjunction with Section 05 Contract Data in volume II, which shall take precedence over the Condition of Contract.</b></p>
--

---

---

# VOLUME II

---

---

## CONTENTS

<u>SECTION</u>	<u>DESCRIPTION</u>	<u>PAGE NO</u>
SECTION 4	FORM OF BID AND QUALIFICATION INFORMATION	19
SECTION 5	BIDDING DATA AND CONTRACT DATA	24
SECTION 6	SPECIFICATIONS	35
SECTION 7	BILL OF QUANTITIES	37
SECTION 8	DRAWINGS	49
SECTION 9	STANDARD FORM [BID]	64
SECTION 10	VAT FORM	66
SECTION 11	CHECK LIST	68

**SECTION 4**

**FORM OF BID**  
**AND**  
**QUALIFICATION INFORMATION**

## FORM OF BID

Name of the Contract: **Construction of Livestock Shed for Faculty of Agriculture at  
Technology Premises, Eastern University, Sri Lanka.**

**To: Vice Chancellor,  
Eastern University, Sri Lanka,**

Gentleman,

1. Having examined the Standard Bidding Document - Procurement of Works (ICTAD/SBD/01,-Second Edition - January 2007 and Addendum 1 and 2 published on October 2009 and February 2011 responsively) Specifications, Drawings and Bill of Quantities and Addenda, if any, for the execution of the above named Works, we the undersigned, offer to execute and complete such Works and remedy any defect therein in conformity with the aforesaid Conditions of Contract, Specifications, Drawings, Bill of Quantities and Addenda, if any, for the sum of Sri Lankan Rupees .....  
.....  
.....(Excluding VAT)  
(SLRs.....) or such other sums as may be ascertained in accordance with the said Conditions.
2. We acknowledge that the Contract Data forms part of our Bid.
3. We undertake, if our Bid is accepted, to commence the works as stipulated in the Contract Data, and to complete the whole of the Works comprised in the Contract within the time stated in the Contract Data.
4. We agree to abide by this Bid for the period of **77 days** from the date fixed for receiving or any extended period and it shall remain binding upon us and may be accepted at any time before the expiration of that period.
5. Unless and until a formal Agreement is prepared and executed this Bid, together with your written acceptance thereof, shall constitute a binding contract between us.
6. We accept/ do not accept the Adjudicator

7. We understand that you are not bound to accept the lowest or any Bid you may receive.

Dated this ..... day of ..... Two Thousand and ..... in the capacity of .....(designation) duly authorised as – *sole proprietor/power of attorney holder* ( *Delete whichever is not applicable*) to sign tenders for and on behalf of .....

.....

(IN BLOCK CAPITALS)

Signature : ..... Seal  
Name : .....  
Address : .....  
.....  
.....  
.....

Witnesses

1. Signature : .....	2. Signature: .....
Name : .....	Name : .....
Address : .....	Address: .....
.....	.....
.....	.....
.....	.....

## Qualification Information

*[To be completed by the Bidder and submitted with the Bid.]*

<b>ICTAD Registration:</b>	<b>Eligibility Requirement</b>	} Should Attach copies of relevant pages from the registration book to confirm your details (attach as annex I).
Registration No		
Grade	C6 and C5	
Speciality	<b>Building Construction</b>	
Validity	<b>Valid at the time of closing of bids and also at the time of award.</b>	
<b>Blacklisted Contactors</b>	Have you been declared as a defaulted contractor by NPA or any other Agency? <b>(Yes/No)</b> If yes provide details (attach as annex II).	
<b>Construction Programme</b>	(attach as annex III)	
<b>Legal Status</b>	Status: Sole Proprietor <input type="checkbox"/> Partnership <input type="checkbox"/> Public Company <input type="checkbox"/> Private Company <input type="checkbox"/> Business Address : ..... ..... ..... Telephone Number : Land :.....Mobile..... Facsimile Number :..... E-mail Address :..... (Power of attorney of signatory of Bidder (if applicable) (attach relevant status copies, as annex IV)	
<b>Signatory of Bid</b>	Sole Proprietor <input type="checkbox"/> Power of Attorney holder <input type="checkbox"/>	
<b>Details of Annual Volume of the Construction works requested as in the Bidding Data Cl. 4.4;</b>	(attach copies of certificates of completion etc, and/or other financial statement or audited report by Chartered Accountant as annex VI)	

<b>Details of Construction works requested as in the Bidding Data Cl. 4.4;</b>	<i>(attach copies of cliental certificates of completion etc, as annex VI)</i>		
<b>Details of construction equipment proposed for the project.</b>	<i>(attach as annex VII)</i>		
<b>Qualification and experience of key staff required as in the Bidding data Cl. 4.4 e</b>	<b>Eligibility Requirements</b>	<b>Bidder's Qualification</b>	
	Category, Experience and Qualification	Required Nos.	Proposed by bidder (Name, experience and Qualification)
	B.Sc. (Civil) Engineer experience in Building Construction - Full time	01	
	Technical Officer - NDT (Civil) or equivalent experience in Building Construction - Full time	01	
	<i>(attach copies of certificates of academic qualification, experience, appointment letter or consent letter etc as annex VIII)</i>		
<b>Details of work plan and method</b>	<i>(attach as annex IX)</i>		
<b>Details of Credit Facilities requested as in the Bidding Data Cl. 4.4(d);</b>	<b>Furnish relevant documents for Rs. 4.0 million.</b> <i>(attach as annex X)</i>		
<b>Details of work in hand as in the Bidding Data Cl. 4.4(e)</b>	<i>(attach relevant document as annex XI)</i>		
<b>Working capital for the work in hand as in the Bidding Data Cl. 4.4(f)</b>	<i>(attach relevant document as annex XI)</i>		

.....  
**Signature of the Bidder**

**Name:**

**Date:**

**Seal**

## **SECTION 5**

### **BIDDING DATA AND CONTRACT DATA**



## Bidding Data

### A. GENERAL

Instructions  
to Bidders  
Clause  
Reference

The Employer is  
Name: **Vice Chancellor, Eastern University,  
Sri Lanka**  
Address: **Vanatharumoolai,  
Chenkalady**

The works consist of Masonry, concrete, steel roof  
frame work, Zn/Al roofing, finishing, electrical &  
plumbing works etc.

SCOPE OF BID

1.2 Intended Completion Date is **One hundred and  
eighty calendar (180) Days** from the Start Date.

1.3 The office for collection of bid forms is  
Name: **Office of the Senior Assistant Registrar /  
Capital Works and Planning**

Address: **Eastern University, Sri Lanka  
Vantharumoolai, Chenkalady.**

The non-refundable fee is **Three Thousand and Five  
hundred (Rs. 3,500.00)**

The Bid forms will be issued **until 15:00** hrs on  
26/11/2020.

2.1 The source of funds is **Consolidated Fund of  
Government of Sri Lanka**

SOURCE OF  
FUNDS

4.2 The registration required  
Specialty **Building Construction**

ELIGIBILITY  
AND  
QUALIFICATIO  
N OF THE  
BIDDER

Grade **ICTAD (CIDA) Grade C6 and C5**

Validity: valid **at the time of closing of the Bids** and  
also **at the time of award**

#### 4.3 **Qualification Information**

The following Information shall be provided in Section 4

- ICTAD Registration;  
Registration Number  
Grade  
Specialty  
Expiry date
- PCA 03 Certificate issued by the Registrar of  
Public Contracts.
- Attach Construction Program
- Details of Company Registration/Incorporation  
of the Company/Business Registration for Sole  
Proprietor or Partnership

- Attach Documents (Power of Attorney or Board Resolution) authorizing the signatory of the Bid.
- Total Turnover from construction work performed for each of the last five years to be confirmed by submission of Audited Financial statements as proof for item 4.4(a) below.
- Experience in works of a similar nature and size for each of the last five years as documentary proof for item 4.4(b) below.
- Construction Equipment.
- Qualification and experience of key Site Management, Project Management and Technical Personal proposed for the Contract as per 4.4(c) below.
- Attach Work plan and methods;
- Details of Credit Facilities as per 4.4 (d) below.
- Documentary proof for item 4.4(e) below.
- Documentary proof for item 4.4(f) below.

#### **4.4 The Bidders Qualification Criteria:**

- a) Average of the annual value of Turnover of construction work performed in last five (05) years shall be at least Sri Lankan Rupees **20 million**. Audited statement in last five years should be submitted along with the Bidding Document.
- b) experience in the construction of at least one contract of a nature and complexity equivalent to the work over the last 05 years (to comply with this requirement, works cited should be at least 70% completed). Documentary evidence obtained from Employer shall be attached as proof for the above which shall include project cost, time duration taken to complete the project, number of storeys and date of completion.
- c) A Civil Engineer in full time, and one Technical Officer with NDT (Civil) or equivalent (full time) should be assigned to the project in addition to the other technical staff needed by the bidder for satisfactory execution of the project.
- d) Minimum amount of liquid assets and /or credit facilities (after setting apart for other contractual commitments) and exclusive of any advance payments which may be made under this contract shall be not less than **SLR 2.5 million**. Credit facility should be addressed to Vice Chancellor, Eastern University, Sri Lanka and should be exclusively for this particular project

- e) Details of work in hand of the bidder duly attested in the form of an affidavit shall be provided with separate statements showing the contract value, percentage of work completed, value of balance work to be done and target date of completion of each of the works listed shall be countersigned by the Engineer/Employer of Consultant.
- f) Documentary proof of to establish the availability of working capital requirement for the work in hand shall be furnished. (Generally working capital required for the work in hand is considered as 20% of value of work in hand).
- g) Even though the bidders meet the above qualifying criteria, they are subjected to be disqualified if they have misled or false statements in proof of the qualification requirements.
- h) Non submission or partial submission of the documents listed above shall lead to rejection of the bid.

**5.0 Add**

A bidder shall submit only one bid.

**ONE BID PER BIDDER**

**8.1 Delete and Add**

The set of bidding documents comprises the documents listed below and addenda issued in accordance with Clause 10:

**CONTENT OF BIDDING DOCUMENT**

Invitation for Bids

Volume 1 :

- Section 1 Instructions to Bidders
- Section 2 Standard Forms (Contract)
- Section 3 Conditions of Contract

Volume 2 :

- Section 4 Form of Bid and qualification Information
- Section 5 Bidding Data and Contract Data
- Section 6 Specification
- Section 7 Bill of Quantities
- Section 8 Drawings
- Section 9 Standard Form (Bid Security)
- Section 10 VAT Form
- Section 11 Check List

- Drawings in Section 8 are available in the **Office of the Senior Assistant Registrar /CW&P,**

Eastern University, Sri Lanka for reference.

- 9.1** Employer's address for the purpose of clarification is;  
Name: **Senior Assistant Registrar / CW&P,**  
Phone: **0652240589, Fax: 0652240585**  
Email : **dr\_capitalworks@esn.ac.lk**  
Address: **Eastern University, Sri Lanka,**  
**Vantharumoolai, Chenkalady.** **CLARIFICATION OF BIDDING DOCUMENTS**
- 11.1** The language of the bidding document shall be English **LANGUAGE OF BID DOCUMENTS COMPRISING THE BID**
- 12.1** **Delete & Add**  
The Bid submitted by the bidder shall comprise the following duly filled and completed in two copies marked "Original" and "Copy"  
Invitation for Bids  
Volume 1 :  
Section 1 Instructions to Bidders  
Section 2 Standard Forms (Contract)  
Section 3 Conditions of Contract  
Volume 2 :  
Section 4 Form of Bid and qualification Information  
Section 5 Bidding Data and Contract Data  
Section 6 Specification  
Section 7 Bill of Quantities  
Section 8 Drawings  
Section 9 Standard Form (Bid Security)  
Section 10 VAT Form  
Section 11 Check list
- 13.3** **Delete**  
.....at the space provided in the B.O.Q." in accordance with the clause 47 of the Condition of Contract  
**Add**  
....."in the Section 10." **BID PRICES**
- 13.4** The Contract is not subjected to price adjustment.
- 15.1** The bid shall be valid up to **77 days** from the deadline for the submission of Bids. **BID VALIDITY**
- 16.1** Bid shall include a Bid Security using the forms included in Section 9. **BID SECURITY**
- 16.2** Bid Security shall be submitted by Bidder.

Bid Security shall be;

- issued by any commercial bank operating in Sri Lanka and approved by the Central Bank of Sri Lanka or Construction Guarantee Fund. (unconditional guarantee) included in Section 09 Standard Forms.
- In favour of **Vice Chancellor, Eastern University, Sri Lanka**
- for an amount **Rs. 150,000.00.**
- Valid for a period up to **12/03/2021**

The agencies acceptable to Employer are:

- a commercial bank operating in Sri Lanka approved by the Central Bank of Sri Lanka;
- a bank based in another country but the guarantee “confirmed” by a bank operating in Sri Lanka approved by the Central Bank of Sri Lanka;
- Construction Guarantee Fund;

<b>17.1</b>	<b>Pre bid meeting -</b>	<b>PRE-BID MEETING</b>
	<b>Contact Senior Assistant Registrar / Capital Works and Planning</b> <b>Phone: 0652240589, Fax: 0652240585</b> <b>Email: dr_capitalworks@esn.ac.lk</b>	
	(a) The Employer’s address for the purpose of Bid submission is	<b>SEALING AND MARKING OF BIDS</b>
<b>19.2</b>	<b>The Chairman</b> <b>Department Procurement Committee,</b> <b>Eastern University, Sri Lanka,</b> <b>Vantharumoolai, Chenkalady.</b>	
	(b) Contract Name: <b>Construction of Canteen at Technology Premises at Eastern University, Sri Lanka</b>	
<b>20.1</b>	The deadline for submission of bids shall be on <b>or before 10.30 am on or before 27/11/2020.</b>	<b>DEADLINE FOR SUBMISSION OF BIDS</b>
<b>29.2(a)</b>	<b>Delete</b> ... “but including Day works, where priced competitively	<b>EVALUATION AND COMPARISON</b>
<b>31.1</b>	Deleted	
<b>31.2</b>	<b>Add to 31.2(C) as follows.</b> If the past performance of a bidder is poor or unsatisfactory in terms of delay, bad workmanship or any other, the bidder shall be subjected to disqualification.	<b>AWARD OF CONTRACT</b> <b>AWARD OF CONTRACT</b>

- 34.1** The amount of Performance Security is **five Percent (5%)** of the Initial Contract Price. **PERFORMANCE SECURITY**
- Performance Security shall be issued by an agency acceptable to Employer using the form for Performance Security (unconditional guarantee) included in Section 02 Standard Forms and it shall be in favour of Vice Chancellor, Eastern University, Sri Lanka.

The agencies acceptable to Employer are:

- a commercial bank operating in Sri Lanka and approved by the Central Bank of Sri Lanka;
- a bank based in another country but the guarantee “confirmed” by a bank operating in Sri Lanka approved by Central Bank of Sri Lanka; or
- Construction Guarantee Fund;

**Add**

- 35.1** Advance Payment Security shall be issued by an agency acceptable to Employer using the form for Advance security (unconditional guarantee) included in Section 02 Standard Forms and it should be valid for 28 Days beyond the Intended Completion Date and shall be in favour of Vice Chancellor, Eastern University, Sri Lanka. **ADVANCE PAYMENT**

The agencies acceptable to Employer are:

- a commercial bank operating in Sri Lanka and approved by the Central Bank of Sri Lanka;
- a bank based in another country but the guarantee “confirmed” by a bank operating in Sri Lanka approved by the Central Bank of Sri Lanka;

- 36.0** **ADJUDICATOR**

**Add**

- The Adjudicator shall be appointed by the ICTAD/CIDA
- Fees and types of reimbursable expenses to be paid to the Adjudicator shall be on a case to case basis and shall be shared equally by the contractor and the Employer.

## Contract Data

*(Please note that the clause nos. given hereunder are that of Conditions of Contract)*

### A. GENERAL

**Clause** The Employer is

**No.** Name: **Vice Chancellor,**  
**1.1** Address: **Eastern University, Sri Lanka**

DEFINITIONS

The Engineer is,

Name: **Works Engineer,**  
**Works Superintendent/Works Supervisors**  
Address: **Eastern University, Sri Lanka**

Engineer Representative: Works Superintendent, EUSL

The works consist of Masonry, concrete, steel roof frame work, Zn/Al roofing, finishing, electrical & plumbing works etc.

The Site is located at **Palachcholai, Vantharumoolai.**

The Start Date shall be within **14** Days from the date of the Letter of Acceptance.

**2.3(10)** The following documents also shall be a part of Contract.  
(i) VAT Form

INTERPRETATION

**8.1** Schedule of other contractors: None

OTHER  
CONTRACTORS

**9.1** Schedule of Key Personnel:

PERSONAL

Category	Required Qualification and Working arrangement
Engineer	B.Sc. (Civil) Engineering experience in building construction - Part Time
Technical Officer	'NDT (Civil) or equivalent experience in building construction - Full time

**13.1** The minimum insurance covers shall be:

- (a) The minimum cover for insurance of the Works and of Plant and Materials is **110%** of the Initial Contract Price. The maximum deductible for insurance of the Works and of Plant and Materials is **five percent (5.0%)** of Initial Contract Price.
- (b) The minimum cover for loss or damage to Equipment is **hundred percent (100%)** of the Equipment cost. The maximum deductible for insurance of Equipment is **five percent (5%)** of the Equipment cost.

INSURANCE

	(c) The minimum cover for insurance of other property is <b>Rs.100,000/-</b>	
	(d) The minimum cover for personal injury or death, <ul style="list-style-type: none"> <li>• For third party and employees of the Employer and other persons engaged by the Employer in the work is <b>Rs.200,000/-</b> per event.</li> </ul>	
<b>13.2</b>	(a) The minimum cover for personal injury or death <ul style="list-style-type: none"> <li>• For the Contractor's workmen is <b>Rs.100,000/-</b> per event.</li> <li>• Contractor's Employees other than workmen is <b>Rs.200,000/-</b> per event.</li> </ul>	
<b>17.1</b>	The Intended Completion Date for the whole of works shall be <b>one hundred and eighty (180) Calendar Days</b> from the Start Date.	<b>INTENDED COMPLETION DATE</b>
<b>21.1</b>	The Site Possession Date shall be within <b>14 Calendar Days</b> from the date of the Letter of Acceptance.	<b>POSSESSION OF THE SITE</b>
<b>24</b>	<b>Add</b> The Adjudicator shall be appointed by Employer and the Contractor with mutual consent of both parties.	<b>DISPUTE RESOLUTION</b>
<b>27.1</b>	The Contractor shall submit a Programme for the Works within <b>7 Calendar Days</b> of delivery of the Letter of Acceptance	<b>PROGRAMME</b>
<b>27.3</b>	The period between Program update is <b>02 Months</b> .	
<b>27.4</b>	The amount to be withheld for late submission of a program is <b>two percent (2%) of the Contract Price</b> .	
<b>35.1</b>	The Defects Liability Period is <b>365 Days</b> .	<b>CORRECTION OF DEFECTS</b>
<b>39.2</b>	Engineer may order Net Variation within <b>10%</b> of the Contract Award Price with the approval of the Employer.	<b>VARIATIONS</b>
<b>40.2</b>	<b>Add at the end of the sub clause</b> <ul style="list-style-type: none"> <li>• Engineer may order Variation within 10% of the Contract Price with the approval of the Employer.</li> <li>• In fixing the appropriate new rates, mark up for overheads and profits shall be limited to maximum of <b>14.0%</b> of the "Basic Cost" of such items. The Basic Cost means cost of materials, labour and equipment".</li> <li>• In fixing such 'Basic Cost', the Engineer shall use the rates for labour, which are used in preparing the "Building Schedule of Rates" and prices for Materials and Equipment shall be used the prevailing market prices and District Rates.</li> <li>• "Building Schedule of Rates" which is available</li> </ul>	<b>PAYMENTS OF VARIATIONS</b>



at Engineer's Office, means the Schedule of Rates per unit of work item. The said rates are determined by the employer for the year in which the services are requested.

<b>44.1(m)</b>	Other Compensation Events: None	<b>COMPENSATION EVENTS</b>
<b>46.1</b>	Not Applicable	<b>CURRENCIES</b>
<b>47.1</b>	<b>- deleted -</b>	<b>PRICE ADJUSTMENT</b>
<b>48.1</b>	<p>The retention from each payment shall be <b>ten (10%) percent</b> of the certified work done.</p> <p>The limit of retention shall be <b>five (5%) percent</b> of the Initial Contract Price.</p>	<b>RETENTION</b>
<b>49.</b>	<p>The amount to be paid is 0.05% of Initial Contract Price per day.</p> <p>The maximum amount of liquidated damages for the whole of the Works shall be <b>ten (10%) percent</b> of the Initial Contract Price.</p>	<b>LIQUIDATED DAMAGES</b>
<b>51.1</b>	<p><b>Add</b></p> <ul style="list-style-type: none"> <li>• Advance Payment Security shall be issued by an agency acceptable to Employer using the form for Advance Security (unconditional guarantee) included in Section 02 Standard Forms and it should be valid for 28 Days beyond the Intended Completion Date and shall be in favour of Vice Chancellor, Eastern University, Sri Lanka.</li> </ul> <p>The agencies acceptable to Employer are:</p> <ul style="list-style-type: none"> <li>• A commercial bank operating in Sri Lanka and approved by the Central Bank of Sri Lanka;</li> <li>• a bank based in another country but the guarantee "confirmed" by a bank operating in Sri Lanka approved by Central Bank of Sri Lanka;</li> </ul>	
<b>52.1</b>	<p>The Performance Security shall be <b>five (5.0%) percent</b> of Initial Contract Price.</p> <ul style="list-style-type: none"> <li>• Performance Security shall be issued by an agency acceptable to Employer using the form for Performance Security (unconditional guarantee) included in Section 02 Standard Forms and it shall be in favour of Vice Chancellor, Eastern University, Sri Lanka.</li> </ul>	<b>SECURITIES</b>

The agencies acceptable to Employer are:

- a commercial bank operating in Sri Lanka and approved by Central Bank of Sri Lanka;
- a bank based in another country but the guarantee “confirmed” by a bank operating in Sri Lanka approved by Central Bank of Sri Lanka;
- Construction Guarantee Fund

53 Deleted

DAY WORKS

58.1 Schedule of operation and maintenance manuals: None.  
As Built Drawings: Contractor shall supply 03 copies of the same within 14 days from the issue of the practical completion certificate. (if applicable)

OPERATION AND MAINTENANCE MANUALS

58.2 The amount to be withheld for non submission of As Built Drawings is one (1%) percentage of the contract price

59.2 Add

TERMINATION

- i. The Contractor does not employ the required Key Personal as stated in the Clause 9.1 of the Contract data, within 07 days after informing him to employ the Personals.

59.2(a) Delete  
.....28 Days.....  
Add  
.....14Days.....

60.1 The percentage to apply to the value of the work not completed, representing the Employer’s additional cost for completing the Works, is **twenty-five (25%) percent** of the balance work.

PAYMENT UPON TERMINATION

# **SECTION 6**

## **SPECIFICATIONS**

## GENERAL SPECIFICATIONS

- 01 Specifications for Building Works – Volume I  
ICTAD Publication No. SCA/4/I  
3<sup>rd</sup> Edition (Revised) – July 2004
- 02 Specifications for Building Works – Volume II  
ICTAD Publication No. SCA/4/II – Sanitary Installations  
2<sup>nd</sup> Edition (Revised) – October 2001
- 03 Specifications for Water Supply Sewerage and Storm Water Drainage Works  
ICTAD Publication No. SCA/3/2  
2<sup>nd</sup> Edition (Revised) – April 2002
- 04 Specifications for Electrical and Mechanical Works  
Associated with Building and Civil Engineering  
ICTAD Publication No. SCA/8  
2<sup>nd</sup> Edition (Revised) – August 2000

Copies of above publications shall be purchased from the Institute for Construction, Training and Development (ICTAD), "Sawsiripaya", 123, Wijerama Mawatha, Colombo 07.

**SECTION 7**  
**BILL OF QUANTITIES**

**BOQ FOR CONSTRUCTION OF LIVESTOCK SHED AT EUSL,  
PALACHCHOLAI.**

ITEM NO	DESCRIPTION	UNIT	QTY	RATE	AMOUNT
---------	-------------	------	-----	------	--------

**SUMMARY**

S.No	DESCRIPTION				AMOUNT
A	CLEARING AND GRUBBING				
B	EXCAVATOR AND EARTH WORK				
C	CONCRETER				
D	FORMWORK & REINFORCEMENT				
E	MASONRY WORKS				
F	FLOOR FINISHES				
G	WALL FINISHES				
H	PAINT FINISHES				
J	METAL WORKS				
K	ELECTRICAL WORKS				
L	STRUCTURAL STEEL WORK				
M	ROOF WORKS AND CEILING				
N	PLUMPING WORKS				
P	SOAKAGE PIT & SEPTIC TANK				
Q	PROVISIONAL SUM				40,000.00
	<b>Sub Total - 01</b>				
	<b>Ddt: Provisional Sum</b>				40,000.00
	<b>Sub Total - 02</b>				
	<b>Ddt: Discount (if any)</b>				
	<b>Sub Total - 03</b>				
	<b>Add: Provisional Sum</b>				40,000.00
	<b>Sub Total - 04 (Carried to Form of Bid)</b>				
	<b>Add: VAT 8%</b>				
	<b>Grand Total</b>				

Amount in Words:
Signature of the Bidder with seal:
Name of Bidder:
Address of Bidder:
Date:
Witness of the Signature:
Name: ..... Signature:.....
Name: ..... Signature:.....

**BOQ FOR CONSTRUCTION OF LIVESTOCK SHED AT EUSL,  
PALACHCHOLAI.**

ITEM NO	DESCRIPTION	UNIT	QTY	RATE	AMOUNT
<b>A</b>	<b>CLEARING AND GRUBBING</b>				
A-1	Setting out for foundation of construction of livestock shed and Site preparation, Clearing site vegetation, removing bushes, shrubs & top soil to a depth not exceeding 150mm and removing all debris away from site. (Approximately 50 Sqrs)	<b>Item</b>	Allow	Sum	
	<b>CLEARING AND GRUBBING CARRIED TO SUMMARY</b>				
<b>B</b>	<b>EXCAVATOR AND EARTH WORK</b>				
B-1	Excavation for foundation, columns & ramp in any material except rock requiring blasting, part return fill in and ram, and surplus disposed of within site as directed.	<b>Cu.m</b>	58.50		
B-2	Supply & filling under floors with clay free approved soil or other approved quality of filling, spread, watered and well rammed in 75mm layers. (Compacted volume) Sample should be submit to approval by enginner before commence the work	<b>Cu.m</b>	370.00		
B-3	Filling around the shed with clay free earth soil or other approved quality of filling, spread, watered and well rammed in 75mm layers. (Compacted volume) -Sample should be submit to approval by enginner before commence the work	<b>Cu.m</b>	180.00		
	<b>EXCAVATOR AND EARTH WORK CARRIED TO SUMMARY</b>				
<b>C</b>	<b>CONCRETER</b>				
C-1	Cement concrete 1:3:6(20) under RRM foundation & under column footings (lean concrete of 50mm thickness)	<b>Sq.m</b>	125.00		
C-2	75 mm thick floor, Worktop, Ramp & Apron Cement concrete 1:2:4(20).	<b>Cu.m</b>	32.50		
C-3	Cement concrete in footings in 1:2:4(20) ground floor using mixer and vibratos	<b>Cu.m</b>	4.00		
C-4	Cement concrete in column shaft in 1:2:4(20) ground floor using mixer and vibreator	<b>Cu.m</b>	7.60		

**BOQ FOR CONSTRUCTION OF LIVESTOCK SHED AT EUSL,  
PALACHCHOLAI.**

ITEM NO	DESCRIPTION	UNIT	QTY	RATE	AMOUNT
C-5	Cement concrete in RCC concrete Plinth beam in 1:2:4(20) using mixer and vibreator	Cu.m	2.60		
C-6	Cement concrete in RCC concrete beam in 1:2:4(20) using mixer and vibreator	Cu.m	6.25		
C-7	Lintol 225mm x 150mm, cement concrete 1:2:4(20),with 2 nos 10mm dia.tor steel and 6mm mild steel c/c 150mm Including form work and poker vibrator and curing	L.m	12.00		
	<b>CONCRETER CARRIED TO SUMMARY</b>				
<b>D-1</b>	<b>FORMWORK &amp; REINFORCEMENT</b>				
D-1.1	Shuttering for column footings	Sq.m	25.00		
D-1.2	Shuttering for column	Sq.m	135.00		
D-1.3	Shuttering for Worktop	Sq.m	3.00		
D-1.4	Shuttering for RCC concrete beam	Sq.m	82.00		
<b>D-2</b>	<b>REINFORCEMENT</b>				
	<b>Tor Steel</b>				
D-2.1	Reinforcement for column footing, shaft, & Beams as per the Drawing	kg	1600.00		
	<b>Mild Steel</b>				
D-2.2	Mild steel rods in reinforcing laid in position and tied with G.I. wire as directed.	kg	380.00		
	<b>FORMWORK &amp; REINFORCEMENT CARRIED TO SUMMARY</b>				
<b>E</b>	<b>MASONRY WORKS</b>				
E-1	Random rubble (150mm - 225mm) masonry in cement mortar 1:5 in wall foundation.	Cu.m	94.00		
E-2	225mm thick brick walls in cement and sand 1:5 in superstructure ground floor	Cu.m	43.00		
E-3	112mm thick brick walls in cement and sand 1:5 in superstructure ground floor	Sq.m	12.75		



**BOQ FOR CONSTRUCTION OF LIVESTOCK SHED AT EUSL,  
PALACHCHOLAI.**

ITEM NO	DESCRIPTION	UNIT	QTY	RATE	AMOUNT
E-4	Drains, 300mm width internally 1:2:4(20) 100mm thick side wall 300mm to 400mm average depth (internally) at two side and 100mm base 50mm screed, wall concrete should bes casted neatly (no plastering) and cement rendered 12mm thick 1:2 complete with expansion joints as necessary for bottom, including necessary excavation, & shuttering. 10mm tor steel c/c 150mm both ways. (As per the Drawing EUSL/CON/LS/2020/4)	L.m	120.00		
E-5	Making 300mm (internally) width iron grating with "L" Iron 1 1/2" x 1 1/2"x 6 mm frame work including horizontal centre member with 4Nos 12mm tor bar with 500mm c/s support 40x40x6mm angle iron including two coats of Anticorrosive (As per the Drawing EUSL/CON/LS/2020/5)	L.m	25.00		
E-6	Curb wall, 1:2:4(20) 150mm thick 600mm depth 3Nos 10mm tor steel horizontally & 10mm vertical c/c 300mm with expansion joints as necessary, including necessary excavation & shuttering. (As per the Drawing EUSL/CON/LS/2020/6)	L.m	115.00		
	<b>MASONRY WORKS CARRIED TO SUMMARY</b>				
<b>F</b>	<b>FLOOR FINISHES</b>				
F-1	Supply and lay gauge 1000 polythene damp proof membrane with 150 mm laps laid under floor concrete, Ramp & Apron.	Sq.m	430.00		
F-2	Rendering 12 mm thick cement and sand 1:2 with neat cement floating to concrete floor.	Sq.m	265.00		
	<b>FLOOR FINISHES CARRIED TO SUMMARY</b>				
<b>G</b>	<b>WALL FINISHES</b>				
G-1	Plastering 16 mm thick to internal walls in cement and sand 1:3 finished smooth with wooden float. (Sand to be sieved). Rate shall included for revels.	Sq.m	335.00		

**BOQ FOR CONSTRUCTION OF LIVESTOCK SHED AT EUSL,  
PALACHCHOLAI.**

ITEM NO	DESCRIPTION	UNIT	QTY	RATE	AMOUNT
G-2	Plastering 16 mm thick to external walls in cement and sand 1:3 finished semi rough with wooden float. (Sand to be sieved). Rate shall included for revels.	Sq.m	85.00		
G-3	12 mm thick Plinth, worktop, Apron & Ramp plastering in 1:3 sand mortar with neat red cement floating	Sq.m	340.00		
	<b>WALL FINISHES CARRIED TO SUMMARY</b>				
<b>H</b>	<b>PAINT FINISHES</b>				
H-1	Preparing surfaces and apply one coat of Acrylic wall filler and two coats of emulsion paint to internal walls	Sq.m	310.00		
H-2	Preparing surfaces and apply one coat of Acrylic wall filler and two coats of approved quality weather shield paint to external walls	Sq.m	85.00		
H-3	Preparing surfaces and apply one coat of Epoxy floor paint for Plinth & worktop.	Sq.m	42.00		
	<b>PAINT FINISHES CARRIED TO SUMMARY</b>				
<b>J</b>	<b>METAL WORKS</b>				
J-1	Supply and fixing D1 type 0.90m x 2.1m sized anadaized bronz aluminium section bar door with 5mm glass with 4mm double side white colour composit board rate including of all necessary hindges, lock ect directed by Engineer. (Sample should be approved by Engineer) (As per the Drawing EUSL/CON/LS/2020/8)	Sq.m	1.90		
J-2	Supplying and fixing of 41mm Aluminium Brownz framed Casment window (1.20m x 1.20m) and 5mm glazed, rate including all necessary fitting items directed by Engineer. (Sample should be approved by Engineer) (As per the Drawing EUSL/CON/LS/2020/8)	Sq.m	1.45		

**BOQ FOR CONSTRUCTION OF LIVESTOCK SHED AT EUSL,  
PALACHCHOLAI.**

ITEM NO	DESCRIPTION	UNIT	QTY	RATE	AMOUNT
J-3	Supplying and fixing of 50 x 50mm box bar - 1.6mm for frame 25x25mm box bar 1.6mm internally with barrel bolt hinges and necessary locking arrangements and 2coats of anticorrosive and 1 coat of enamel paint . (Sample should be approved by Engineer) (As per the Drawing EUSL/CON/LS/2020/8)	Sq.m	1.60		
J-4	Supplying and fixing 50mm dia GI pipe (2.30mm thk) of guard rail including 02 coat of Anticorrosive paint. (Sample should be approved by Engineer) (As per the Drawing EUSL/CON/LS/2020/9)	Nos	26.00		
J-5	Supplying and fixing 20mm Mild steel ring for Cow tying purpose. including 02 coat of Anticorrosive paint. (Sample should be approved by Engineer) (As per the Drawing EUSL/CON/LS/2020/9)	Nos	30.00		
	<b>METAL WORKS CARRIED TO SUMMARY</b>				
<b>K</b>	<b>ELECTRICAL WORKS</b>				
K-1	Lamp point (light) wiring only (wiring and installation (including supply of all materials) of the below light points using approved type PVC insulated PVC sheathed 1mm <sup>2</sup> copper cable drawn through securely fixed concealed PVC conduit or casing)	Nrs	22.00		
K-2	Fan point wiring only (Wiring & installation (including supply of all material, earth wire & switch) of the above ceiling fans using approved type 1mm <sup>2</sup> PVC/PVC copper cable drawn through securely fixed PVC conduits)	Nrs	1.00		
K-3	Supplying and fixing 1200mm long 36W LED flourcent lamp set Guarantee cards should be provided from accredited agent before installation. Sample should be approved by Engineer.	Nrs	22.00		
K-4	Supply and installation of approved quality Ceiling fan 1400mm dia. c/w 5 speed fan regulator all necessary accessories (without wiring )	Nrs	1.00		

**BOQ FOR CONSTRUCTION OF LIVESTOCK SHED AT EUSL,  
PALACHCHOLAI.**

ITEM NO	DESCRIPTION	UNIT	QTY	RATE	AMOUNT
K-5	13amp socket outlet wiring to be carried out with 2 x 2.5mm <sup>2</sup> or twin wire pvc insulated pvc sheathed copper cables and 2.5mm <sup>2</sup> earth cable terminated in a terminal wired in concealed conduit in wall and slab/ceiling supplied and installed in working order	Nrs	22.00		
K-6	Supplying and fixing ABC Box type 900/600	Nrs	1.00		
K-7	Supplying and fixing Main, 63Amps.	Nrs	1.00		
K-8	Supplying and fixing RCCB, 63Amps.	Nrs	1.00		
K-9	Supplying and fixing M.C.Bs 6,12,15,20 amps.	Nrs	12.00		
K-10	Supplying and fixing Earth electrode 12mm brass.	Nrs	1.00		
K-11	Supply and fixing 4 Sq.mm Cu/pvc/pvc pvc coated single supply main wire with necessary fittings	L.m	5.00		
K-12	Supply and fixing of Service bracket with necessary fittings as per the drawing	L.m	5.00		
	<b>ELECTRICAL WORKS CARRIED TO SUMMARY</b>				
<b>L</b>	<b>STRUCTURAL STEEL WORK</b>				
L-1	Supply and place in position steel roof truss (WEB) - (approx: Span 7.50m). - complete with double member exterior (2"x2"x6mm Angle Iron) and single member interior (1-1/2"x1-1/2"x 6mm Angle Iron), 6 mm gusset plate, 16 mm dia. 9" rag bolts, 6 mm base plate welded and application of two coats of anti-corrosive paint all as per detail drawing. plate etc.	Nos	15.00		
L-2	Supply & fixing of 100 x 50mm -2.00mm thick GI box bar with anticorrosive paint for welded area. Sample should be approved by Engineer.	L.m	450.00		

**BOQ FOR CONSTRUCTION OF LIVESTOCK SHED AT EUSL,  
PALACHCHOLAI.**

ITEM NO	DESCRIPTION	UNIT	QTY	RATE	AMOUNT
L-3	Supplying, Fabricating and Fixing of Safety Grill using Ampli mesh to windows. (Rate shall including of necessary "m" channels, 1" pop rivert, Screws,rubber beading etc). Sample should be approved by Engineer.'	Sq.m	1.50		
	<b>STRUCTURAL STEEL WORKS CARRIED TO SUMMARY</b>				
<b>M</b>	<b>ROOF WORKS AND CEILING</b>				
M-1	Supplying & fixing of corrugated asbestos sheets to roof on existing frame work with necessary coach screws and limpet washers or "J" hook bolts. (Sample should be approved by Engineer)	Sq.m	440.00		
M-2	Asbestos ridging complete with roofing screws or hooks. (Sample should be approved by Engineer)	L.m	44.50		
M-3	Supply and fixing flat suspension asbestos free 600x600mm ceiling in second floor with "L" & "T" Al bars frame works rate including steel rods, butterfly clip and two coated of emulsion paint for asbestos sheet & etc. (materials should approved by Engineer)	Sq.m	8.00		
	<b>ROOF WORKS AND CEILING CARRIED TO SUMMARY</b>				
<b>N</b>	<b>PLUMPING WORKS</b>				
N-1	Supplying and fixing of PVC 25mm Ball valve.	Nos	17.00		
N-2	Supply and laying 25mm PVC pipe (PNT 14/ PN 16) including of all necessary joints, bends, endcap ect	L.m	50.00		
N-3	Supply and laying 63mm PVC pipe (PNT 14/ PN 16) including of all necessary joints, bends, endcap ect	L.m	100.00		
N-4	Supplying and fixing of Stainless steel single ball,single drain sink with waste plugh and swan neck tap (Rate shall including all the necessary fittings)	Nos.	1.00		
	<b>PLUMPING WORKS CARRIED TO SUMMARY</b>				

**BOQ FOR CONSTRUCTION OF LIVESTOCK SHED AT EUSL,  
PALACHCHOLAI.**

ITEM NO	DESCRIPTION	UNIT	QTY	RATE	AMOUNT
P	<b>SOAKAGE PIT &amp; SEPTIC TANK</b>				
P-1	<u>Soakage Pit (Internal Size-1.83m dia, 3m depth) (As per the Drawing EUSL/CON/LS/2020/10)</u>				
P-1.1	Excavation for soakage pit to a depth not exceeding 2.0m in any material except rock requiring blasting part return fill in and ram and surplus disposed within the site as directed by the Engineer. Rate include for shoring of sides of excavated pits.	m <sup>3</sup>	12.00		
P-1.2	1:2:4(20) concrete in bottom ring beam, top capping beam, cross beam & slab cover	m <sup>3</sup>	1.00		
P-1.3	Form work in bottom ring beam, top capping beam, cross beam & slab cover	m <sup>2</sup>	12.50		
P-1.4	10mm, 12mm dia tor rods in reinforcing in foundation bent to shape, laid in position and tied with G.I. wire as directed.	Kg	80.00		
P-1.5	6mm dia rods in reinforcing in foundation bent to shape, laid in position and tied with G.I. wire as directed.	Kg	25.00		
P-1.6	225mm thk brick work with 1:5 cement sand motor	m <sup>3</sup>	3.50		
P-1.7	16mm thick 1:3 cement sand mortar finished smooth plastering to wall	m <sup>2</sup>	30.00		
P-1.8	Supplying and laying porus material as fliter material (geotec material)	Item	Allow	Sum	
P-1.9	Supplying and fixing of 110mm dia "T" and necessary socket as per the drawing	Nos	1.00		
P-1.10	Supplying and fixing P.V.C 63mm dia (PNT 11) including of all necessary joints, bends, endcap ect	L.m	20.00		
P-1.11	Supplying and fixing P.V.C 110mm dia pipe. (PNT 9) including of all necessary joint, bends, cleaning eyes ect	L.m	6.00		
P-1.12	Drains PVC 110mm laid on cement conc. 150mm thick up to 600mm depth of invert including excavation & cement conc. Hunching 1:3:6(40).	L.m	6.00		
	Total amount per 1No				
	<b>Total amount per 2No</b>			<b>(A)</b>	

**BOQ FOR CONSTRUCTION OF LIVESTOCK SHED AT EUSL,  
PALACHCHOLAI.**

ITEM NO	DESCRIPTION	UNIT	QTY	RATE	AMOUNT
P-2	<b>Septic Tank (External Size-1.80m x3.0m) (As per the Drawing EUSL/CON/LS/2020/11)</b>				
P-2.1	Excavation for foundation in any material except rock requiring blasting part return fill in and ram and surplus disposed within the site as directed by the Engineer. Rate include for shoring of sides of excavated pits.	m <sup>3</sup>	13.00		
P-2.2	10mm, 12mm dia rods in reinforcing in foundation bent to shape, laid in position and tied with G.I. wire as directed.	Kg	90.00		
P-2.3	6mm dia rods in reinforcing in foundation bent to shape, laid in position and tied with G.I. wire as directed.	Kg	20.00		
P-2.4	Form work in base, walls & top slab	m <sup>2</sup>	15.00		
P-2.5	1:2:4(20),C20 Concrete in Base, Columns and top slab cover	m <sup>3</sup>	2.00		
P-2.6	225mm thk brick work with 1:5 cement sand motor	m <sup>3</sup>	4.00		
P-2.7	16mm thick 1:3 cement sand mortar finished smooth plastering to wall	m <sup>2</sup>	30.00		
P-2.8	20mm thick 1:2 cement rendering	m <sup>2</sup>	4.50		
P-2.9	Supplying and fixing of 110mm dia "T" and necessary socket as per the drawing	Nos	1.00		
	Total amount per 1No				
	Total amount per 2No			(B)	
	<b>SOAKAGE PIT &amp; SEPTIC TANK CARRIED TO SUMMARY</b>			<b>(A)+(B)</b>	
<b>Q</b>	<b>PROVISIONAL SUM</b>				
Q-1	Allow for Provisional sum for Landscaping arrangement as per land profile and dewatering ect.	Item	Allow	Pro.Sum	40,000.00
	<b>PROVISIONAL SUM CARRIED TO SUMMARY</b>				<b>40,000.00</b>

# **SECTION 8**

## **DRAWINGS**



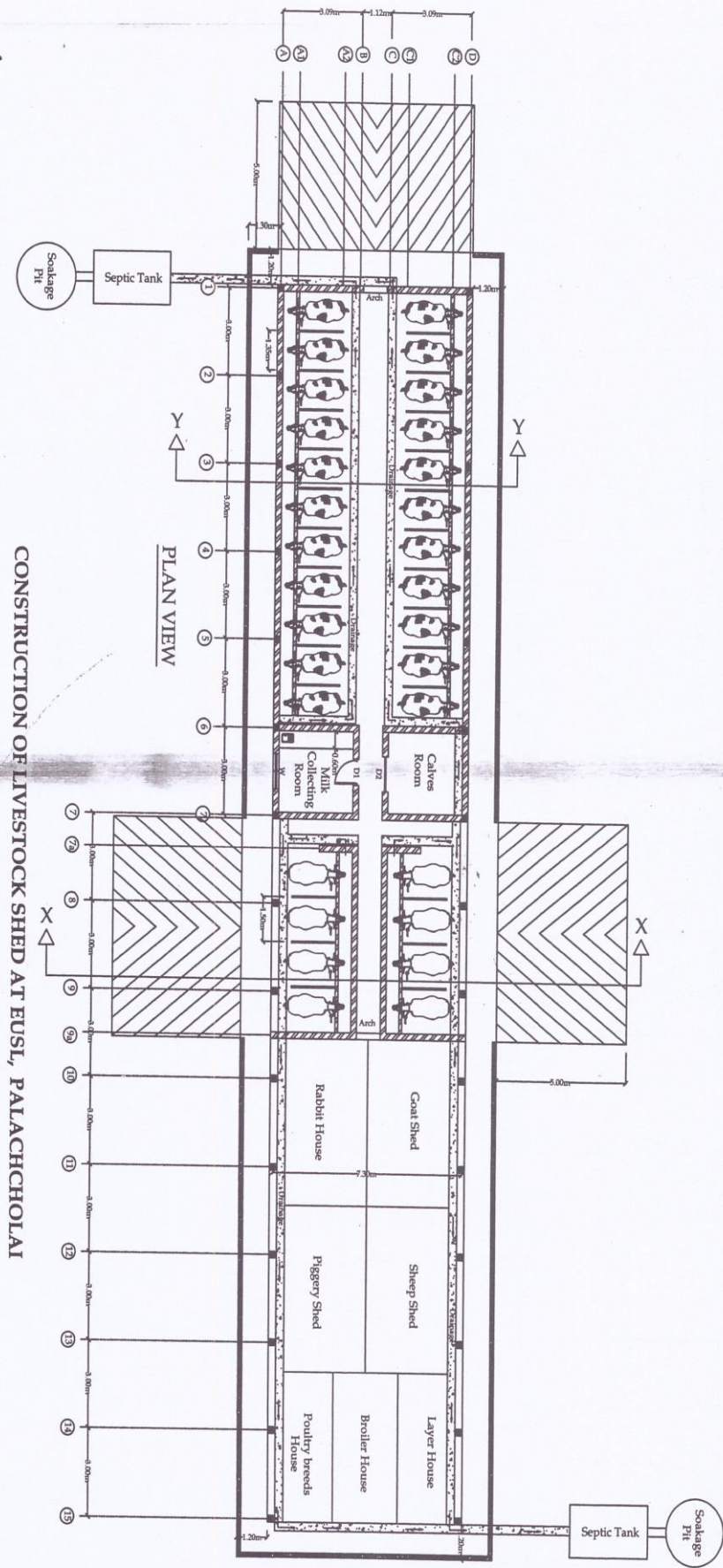

CONSTRUCTION OF LIVESTOCK SHED AT EUSI, PALACHCHOLAI

*Arpan*

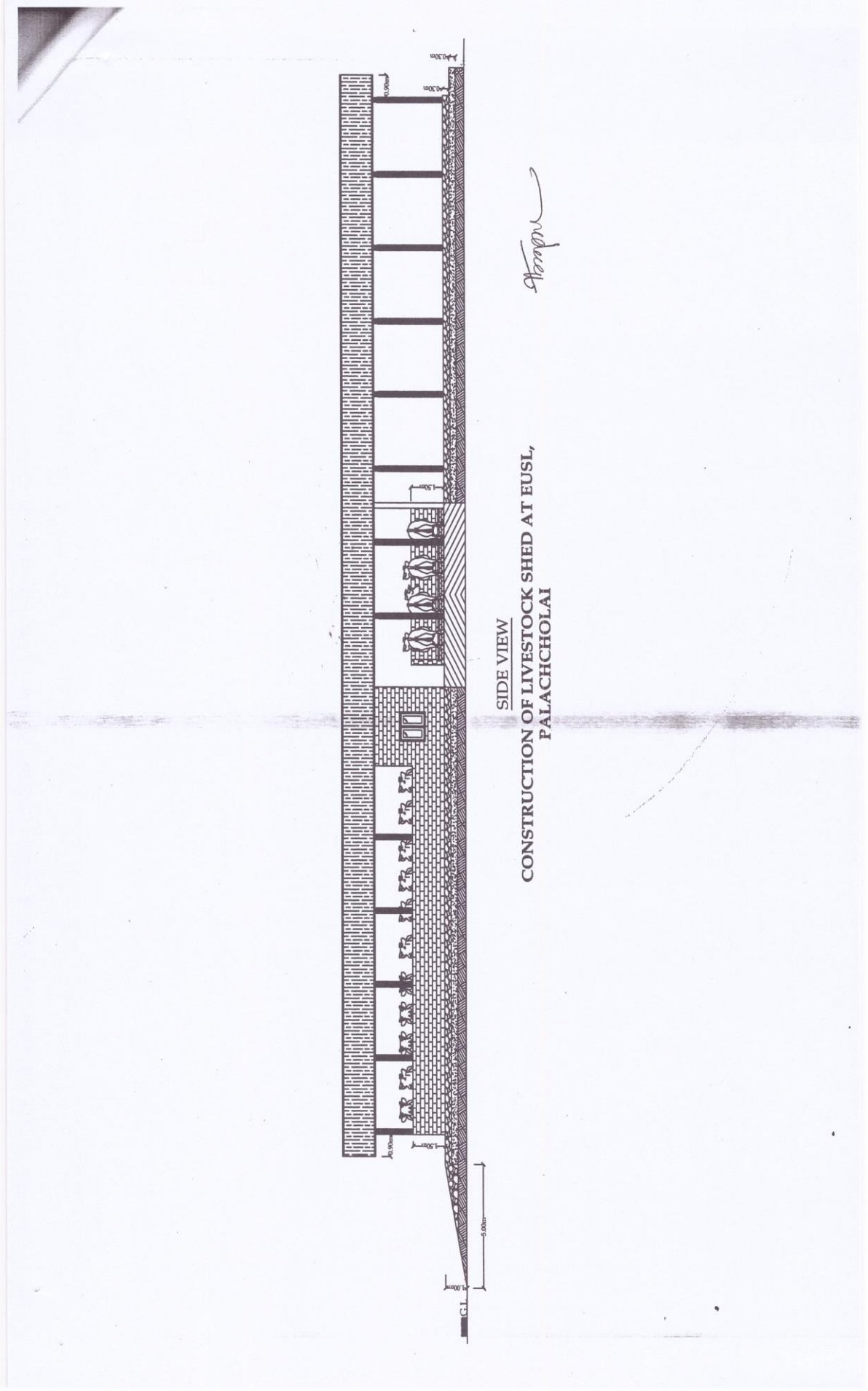

SIDE VIEW  
CONSTRUCTION OF LIVESTOCK SHED AT EUSL,  
PALACHCHOLAI

*Atomp*

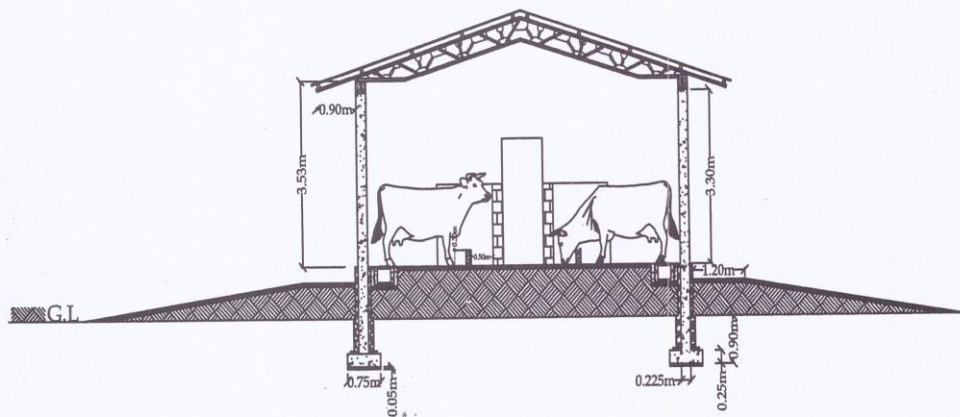

SECTION X-X

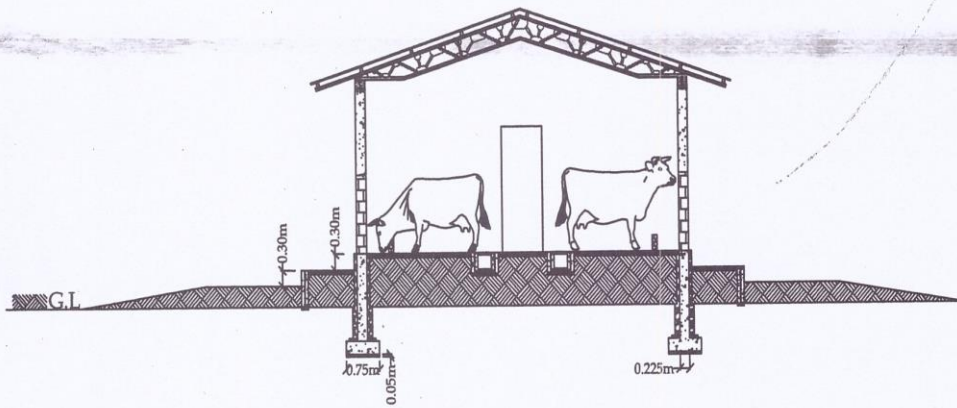

SECTION Y-Y

**CONSTRUCTION OF LIVESTOCK SHED AT EUSL,  
PALACHCHOLAI**

*Handwritten signature*

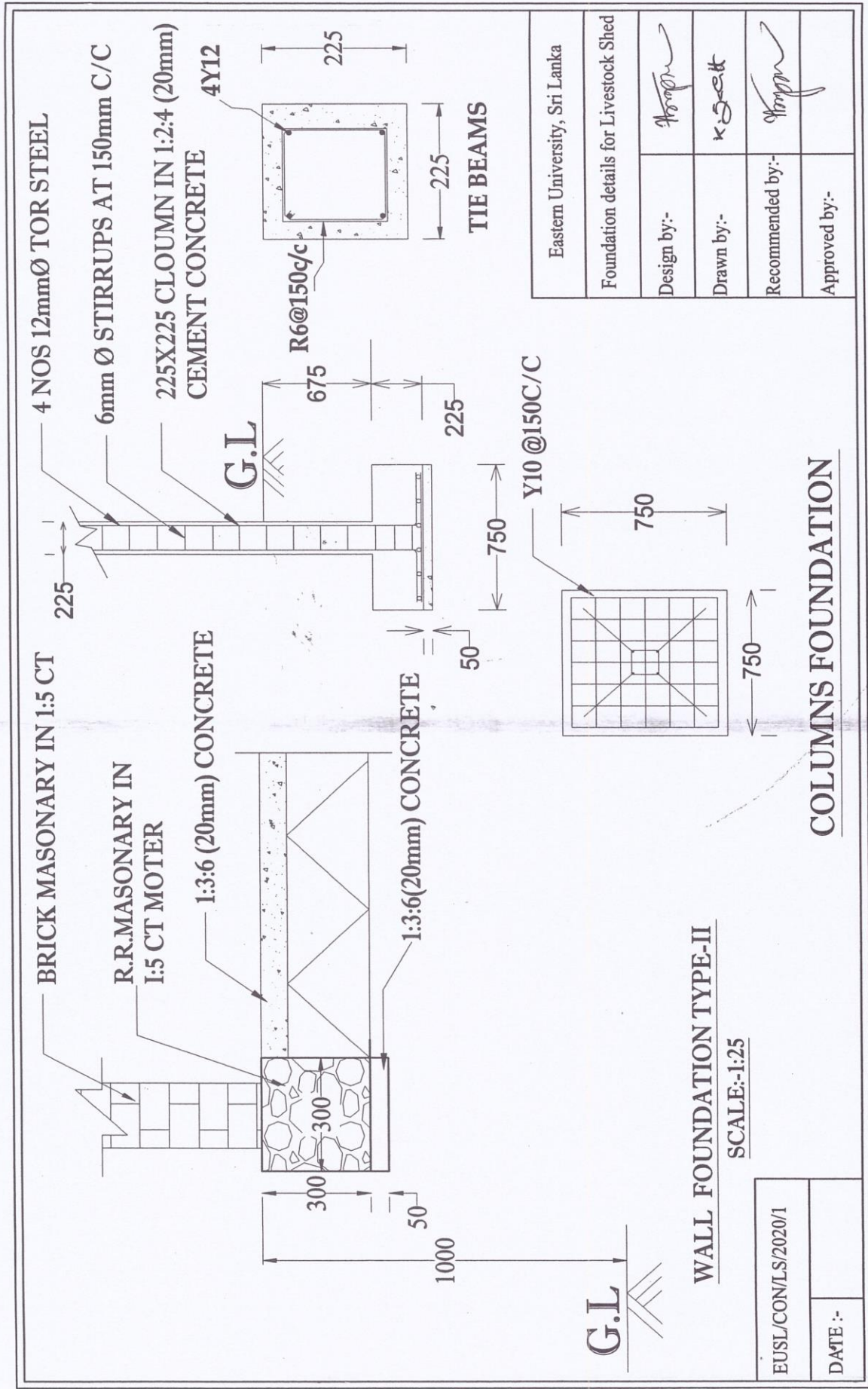

**WALL FOUNDATION TYPE-II**

SCALE:-1:25

EUSL/CON/LS/2020/1

DATE :-

Eastern University, Sri Lanka	
Foundation details for Livestock Shed	
Design by:-	<i>[Signature]</i>
Drawn by:-	<i>[Signature]</i>
Recommended by:-	<i>[Signature]</i>
Approved by:-	

**COLUMNS FOUNDATION**

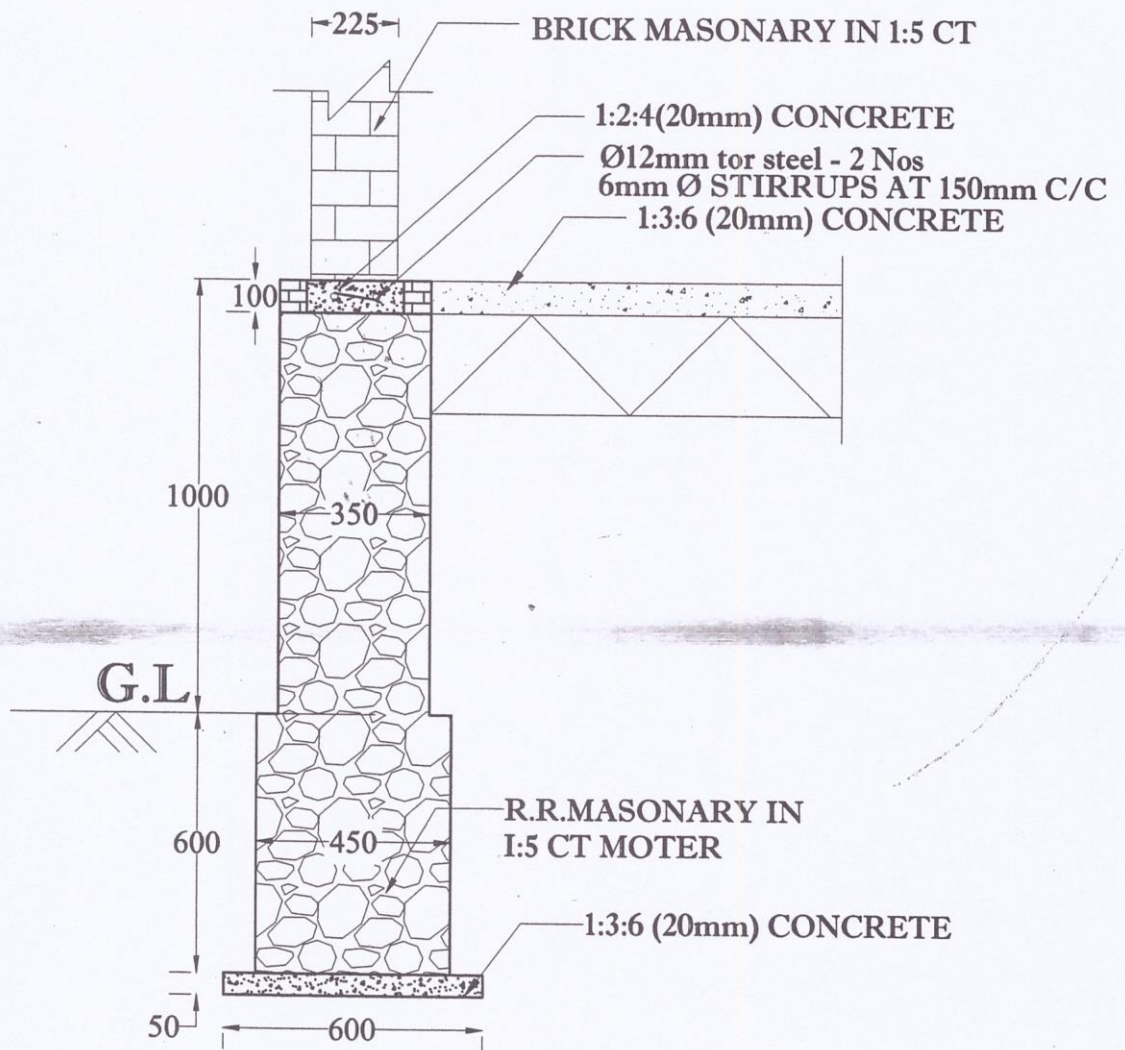

**WALL FOUNDATION TYPE-I**  
(ALL MEASUREMENTS IN MM)

EUSL/CON/LS/2020/2	
DATE :-	

Eastern University, Sri Lanka	
Foundation details for Livestock Shed	
Design by:-	<i>[Signature]</i>
Drawn by:-	<i>K.S.C.A.</i>
Recommended by:-	<i>[Signature]</i>
Approved by:-	

R.R.MASONARY IN  
1:5 CT MOTER

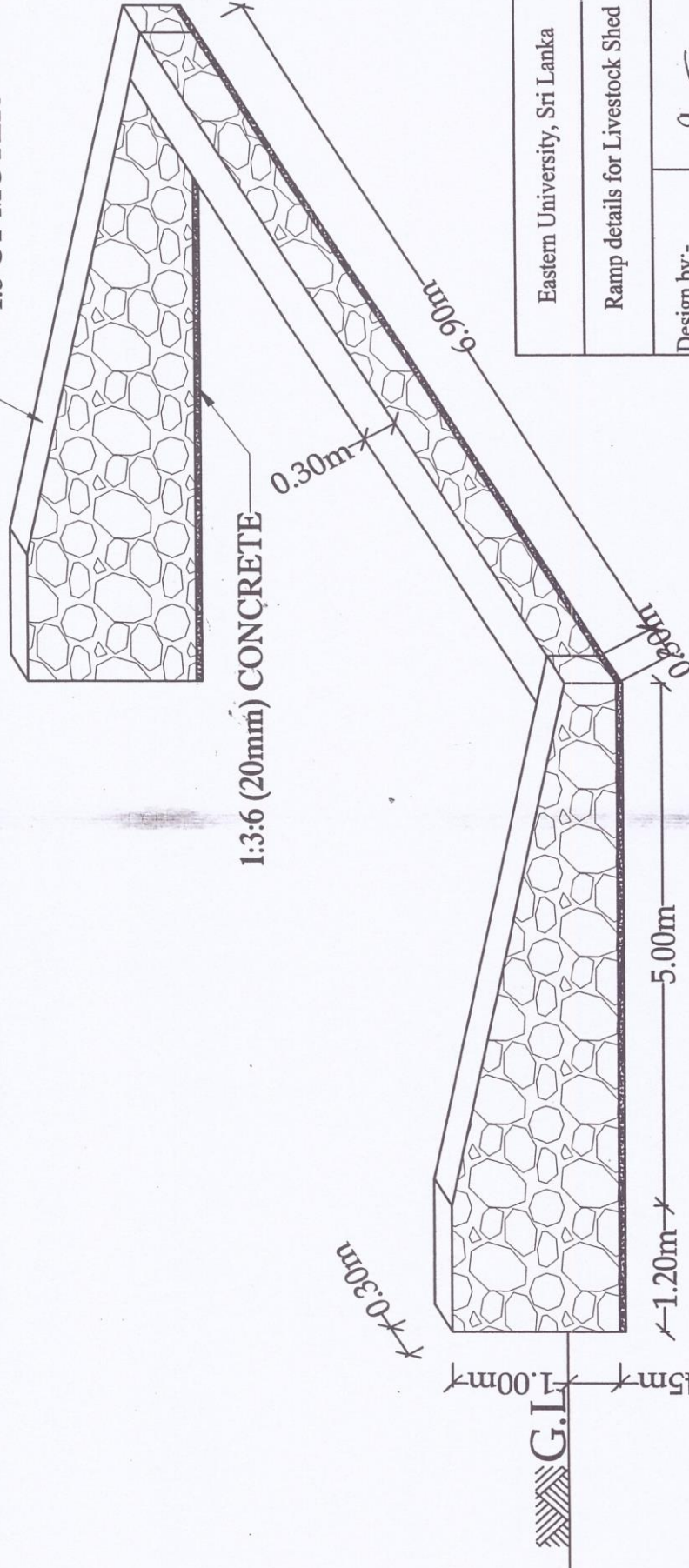

1:3:6 (20mm) CONCRETE

**RAMP DETAILS**

Eastern University, Sri Lanka	
Ramp details for Livestock Shed	
Design by:-	<i>[Signature]</i>
Drawn by:-	K. S. S. S. S.
Recommended by:-	<i>[Signature]</i>
Approved by:-	

EUSL/CON/LS/2020/3	
DATE :-	

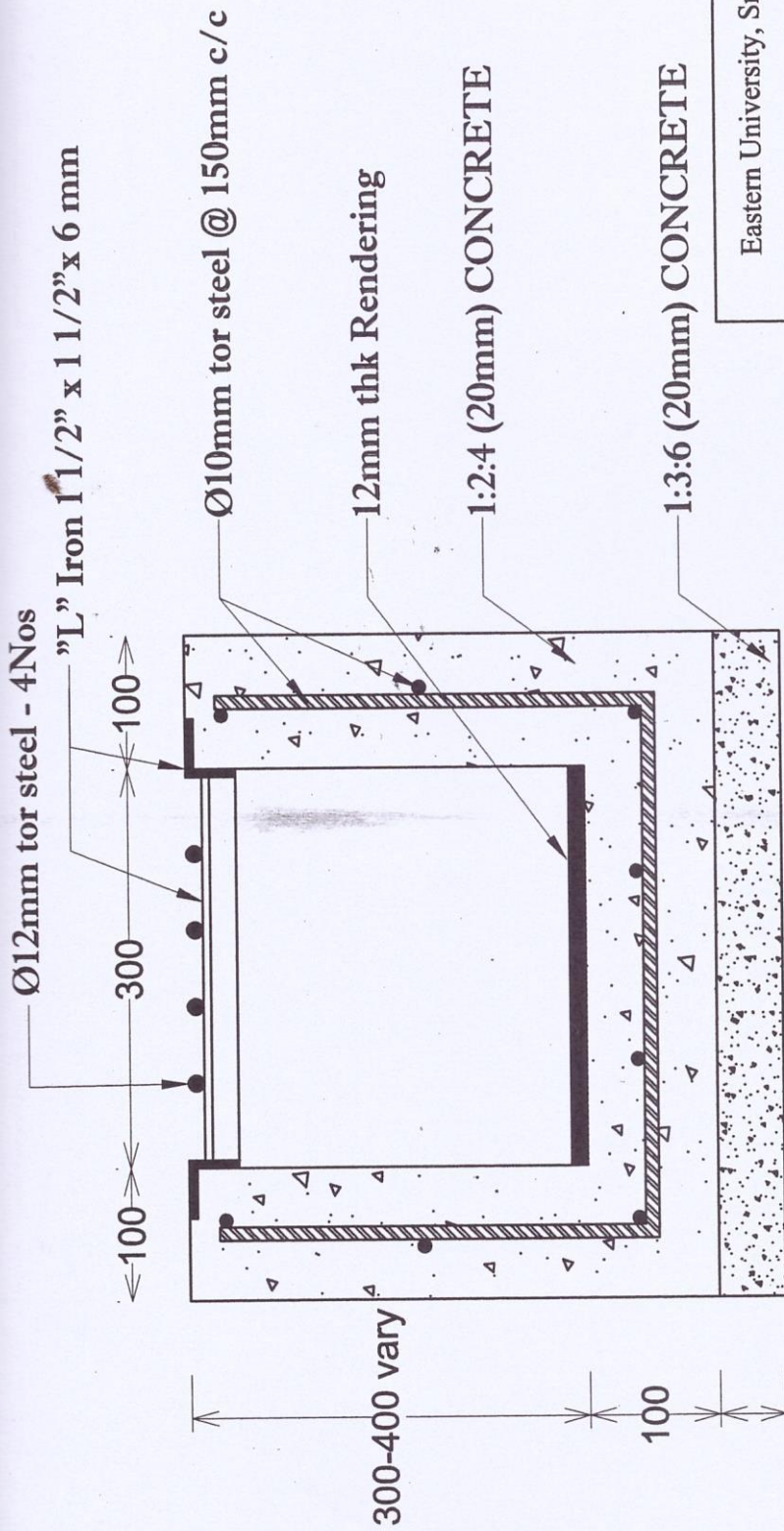

**DRAINAGE DETAILS**

Eastern University, Sri Lanka	
Drainage details for Livestock Shed	
Design by:-	<i>Handwritten Signature</i>
Drawn by:-	<i>Handwritten Signature</i>
Recommended by:-	<i>Handwritten Signature</i>
Approved by:-	

EUSL/CON/LS/2020/4
DATE :-

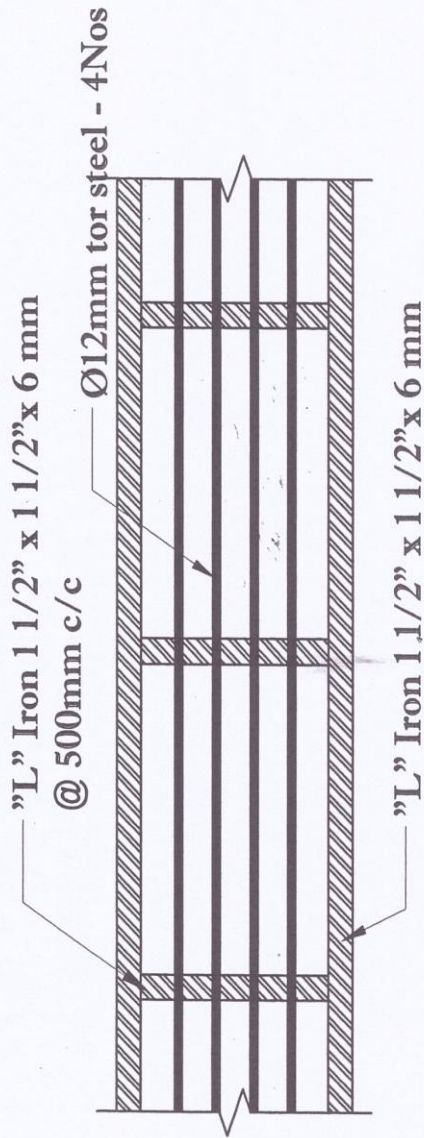

### IRON GRATING DETAILS

ÉUSL/CON/LS/2020/5

DATE :-

Eastern University, Sri Lanka	
Iron Grating details for Livestock Shed	
Design by:-	<i>[Signature]</i>
Drawn by:-	<i>[Signature]</i>
Recommended by:-	<i>[Signature]</i>
Approved by:-	



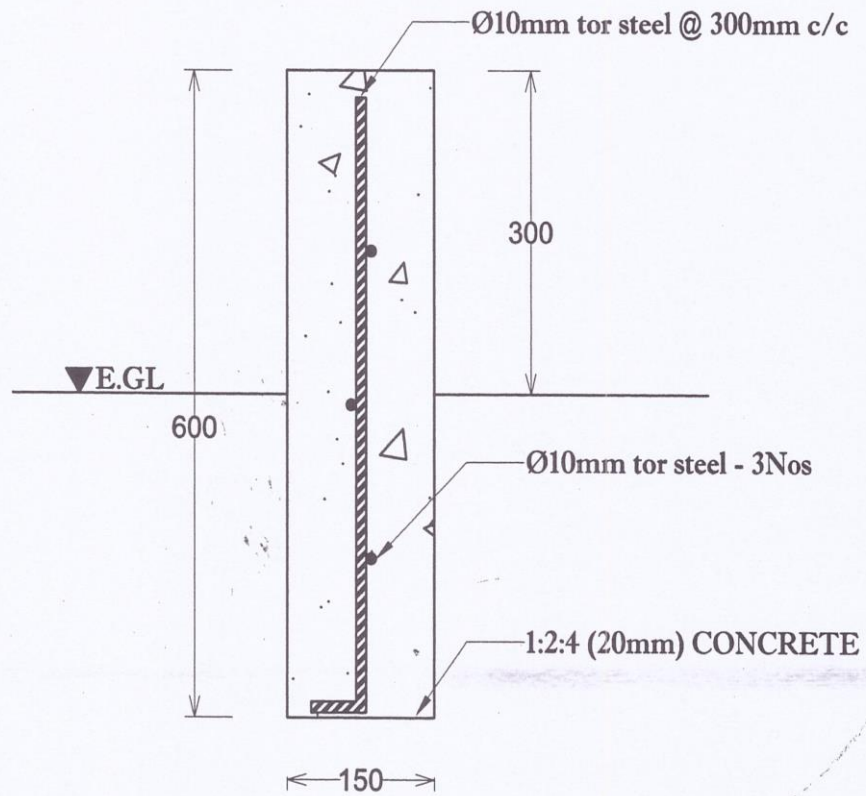

**CURB WALL DETAILS**

EUSL/CON/LS/2020/6	
DATE :-	

Eastern University, Sri Lanka	
Curb wall details for Livestock Shed	
Design by:-	<i>[Signature]</i>
Drawn by:-	<i>[Signature]</i>
Recommended by:-	<i>[Signature]</i>
Approved by:-	

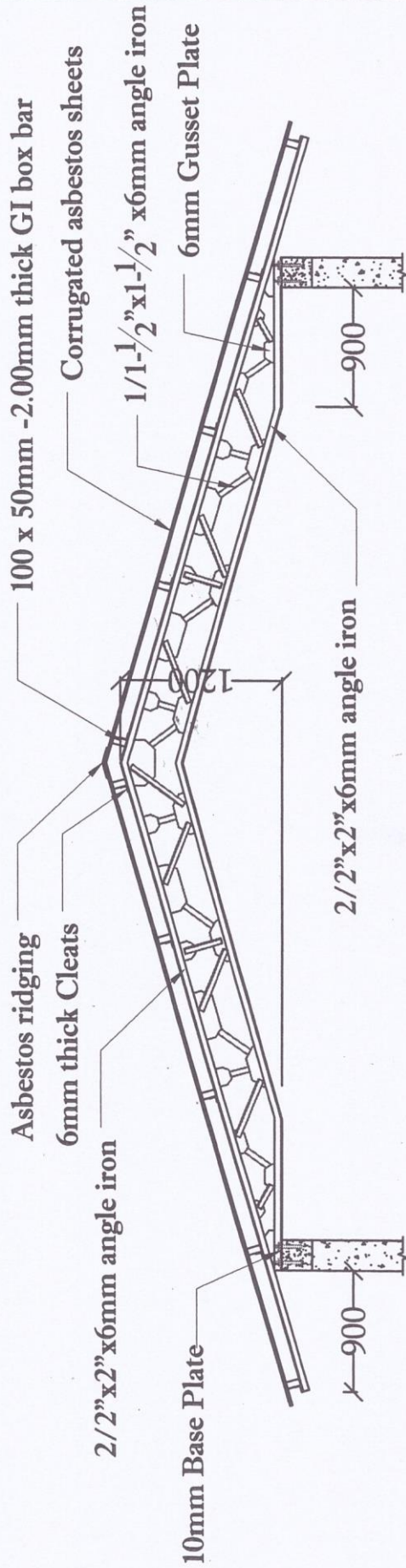

## STEEL TRUSS

Eastern University, Sri Lanka

Steel Truss details for Livestock Shed

Design by:-

*K. S. S. S.*

Drawn by:-

*K. S. S. S.*

Recommended by:-

*K. S. S. S.*

Approved by:-

EUSL/CON/LS/2020/7

DATE :-

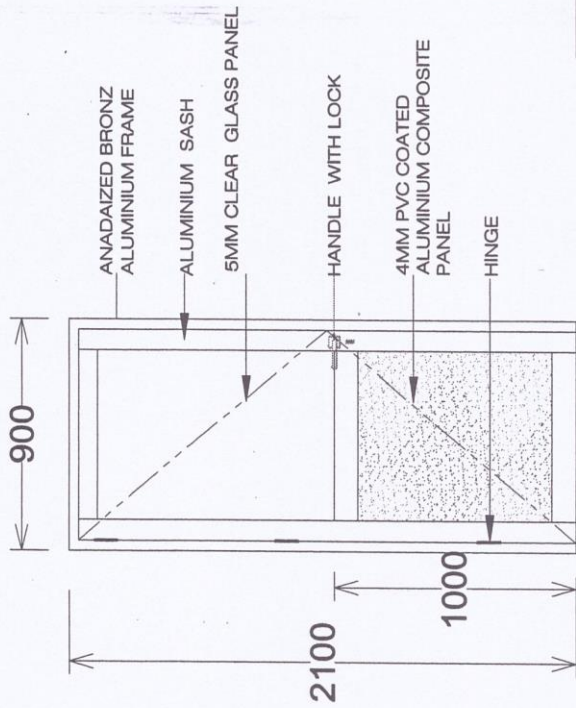

**DOOR (D1) DETAILS**

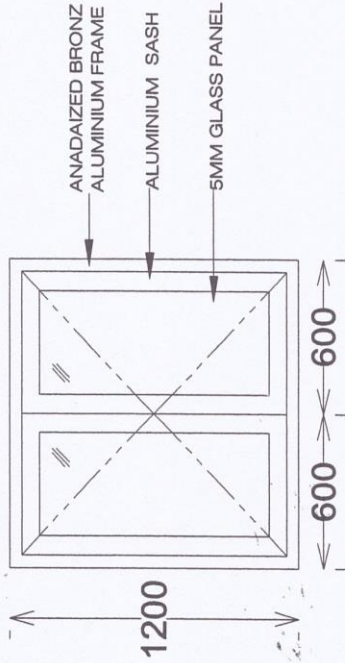

**WINDOW (W) DETAILS**

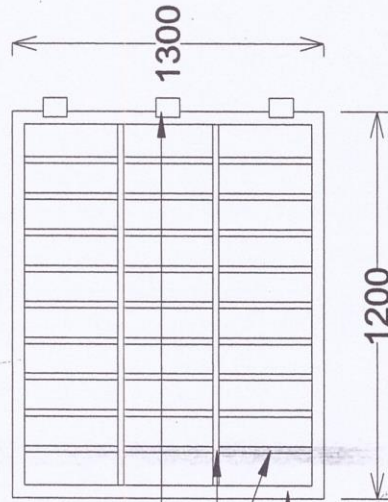

**DOOR (D2) DETAILS**

Eastern University, Sri Lanka	
Door & Windows details for Livestock Shed	
Design by:-	<i>Noropen</i>
Drawn by:-	<i>K. Seneett</i>
Recommended by:-	<i>Noropen</i>
Approved by:-	

EUSL/CON/LS/2020/8	
DATE :-	

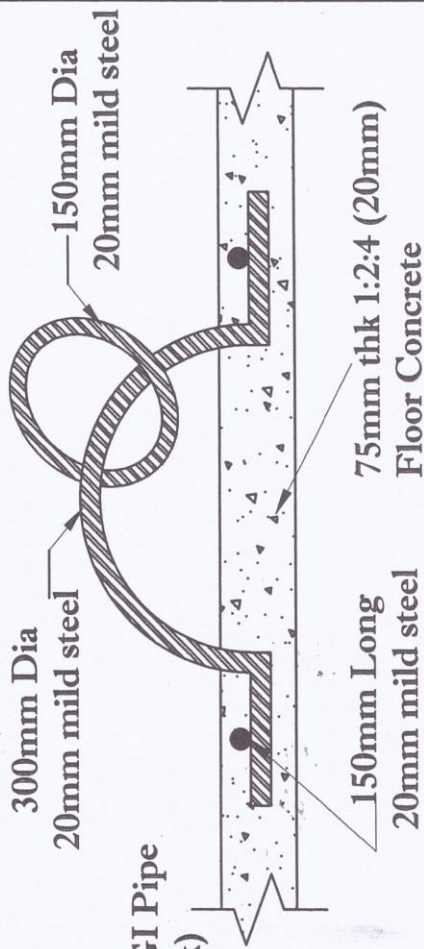

### COW TIE DETAILS

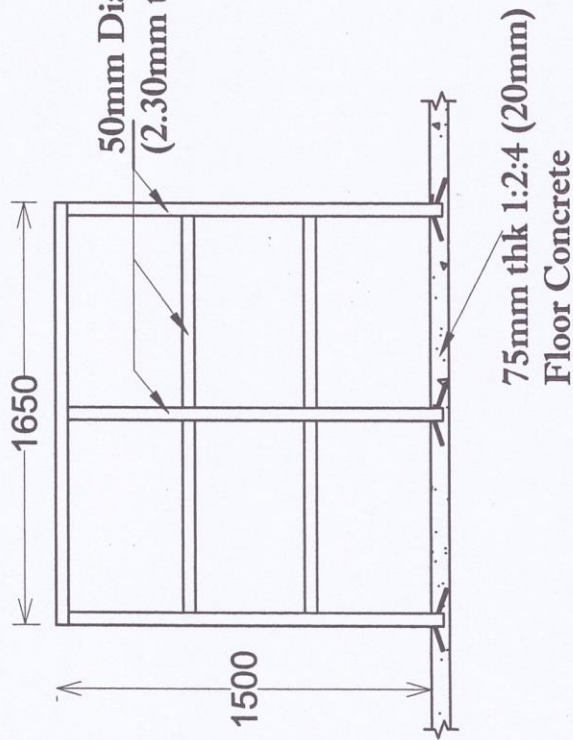

### GUARD RAIL DETAILS

Eastern University, Sri Lanka	
Livestock Shed	
Design by:-	<i>[Signature]</i>
Drawn by:-	<i>K. G. E. E. T.</i>
Recommended by:-	<i>[Signature]</i>
Approved by:-	

EUSL/CON/LS/2020/9
DATE :-

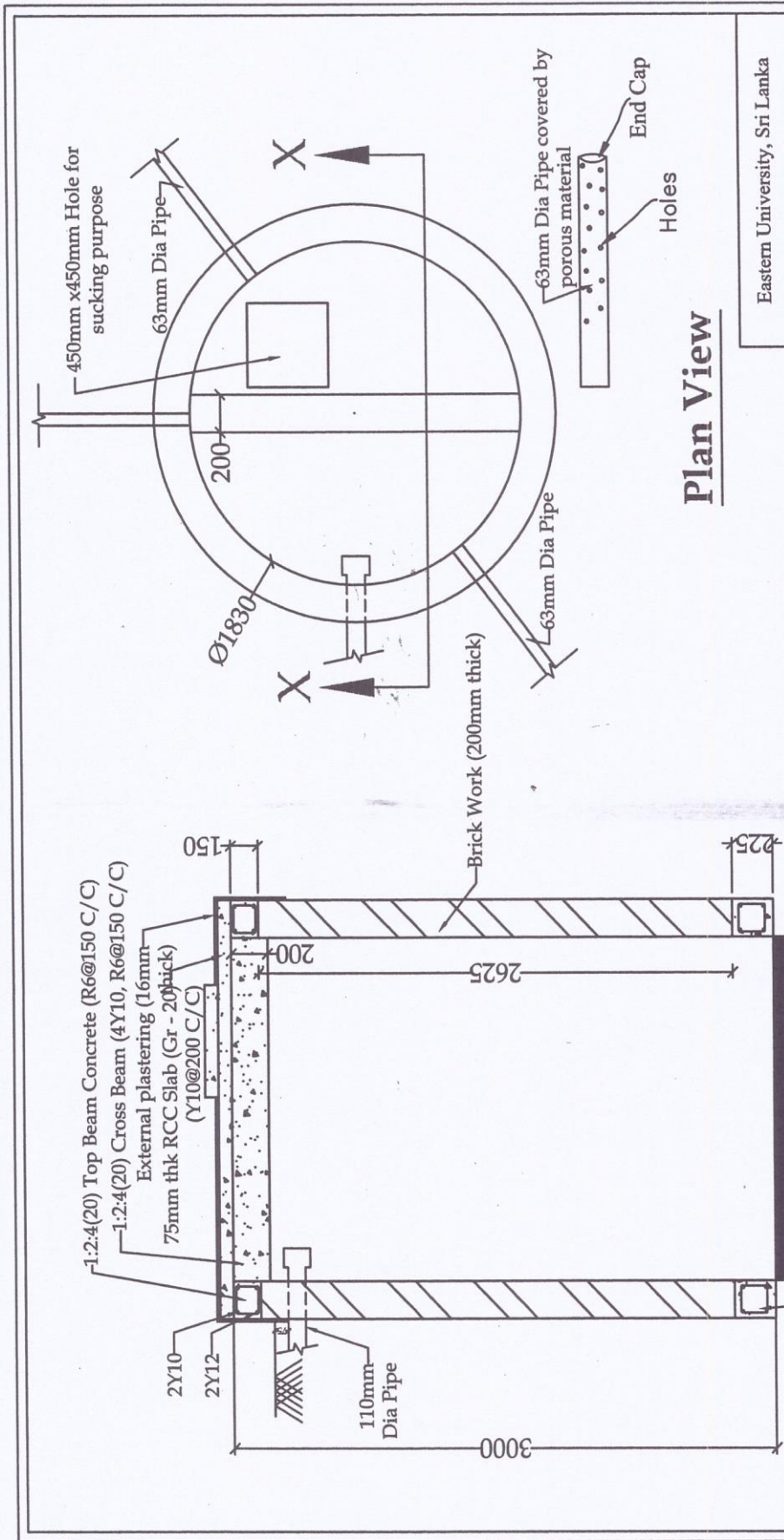

**Plan View**

**X-X Section View**

**SOAKAGE PIT'S DETAILS**

(ALL MEASUREMENTS IN MM)

Eastern University, Sri Lanka	
Sketch for Soakage pits	
Design by:-	<i>Arupam</i>
Drawn by:-	<i>K. S. E. K.</i>
Recommended by:-	<i>Arupam</i>
Approved by:-	

EUSL/CON/LS/2020/10
DATE :-

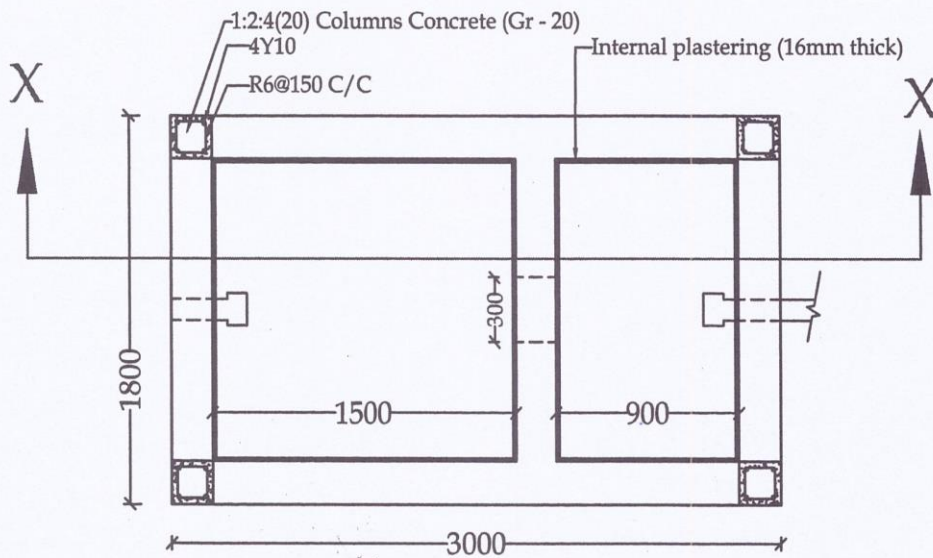

**Plan View**

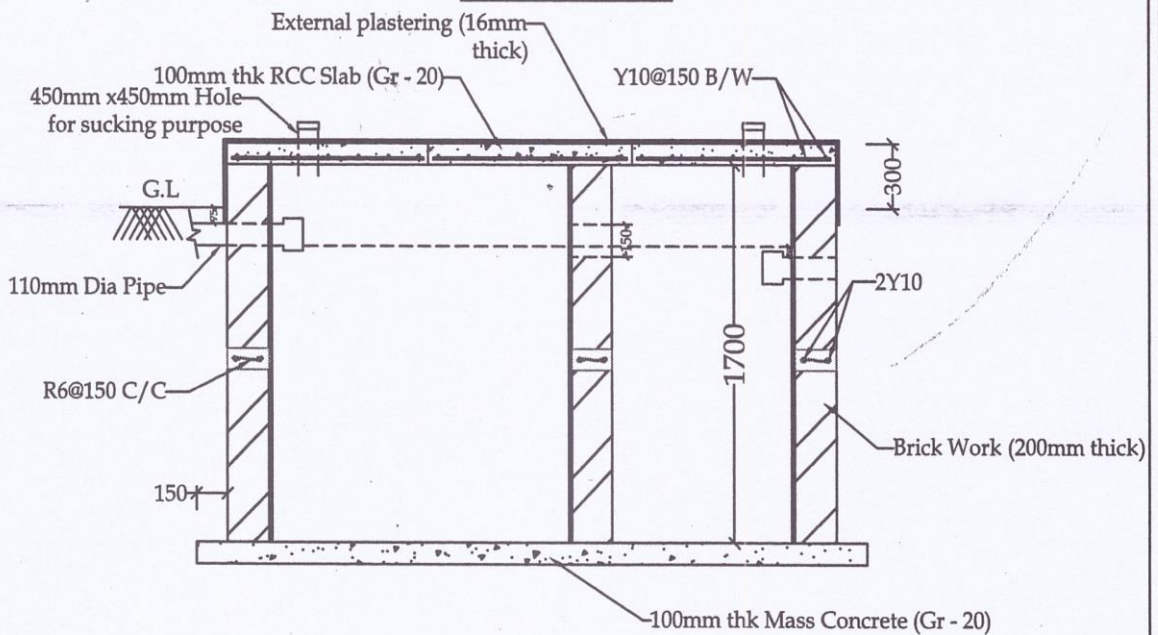

**X-X Section View**

**SEPTIC TANK'S DETAILS**  
(ALL MEASUREMENTS IN MM)

EUSL/CON/LS/2020/11	
DATE :-	

Eastern University, Sri Lanka	
Sketch for Septic Tank	
Design by:-	<i>[Signature]</i>
Drawn by:-	<i>K. Saeed</i>
Recommended by:-	<i>[Signature]</i>
Approved by:-	

# **SECTION 09**

## **STANDARD FORM [BID SECURITY]**

## **Form of Bid Security**

*[this Guarantee form shall be filled in accordance with the instructions indicated in brackets]*

**Issuing Agency:** .....

*-[insert issuing agency's name and address of Issuing branch or Office]*

**Beneficiary:** Vice Chancellor,  
Eastern University, Sri Lanka

**Date:** ..... *[insert (by issuing agency) date]*

**BID GURANTEE No:** ..... *[insert (by issuing agency) number]* We have been informed that ..... *[insert (by issuing agency) name of the Bidder]* (hereinafter called "the Bidder") has submitted to you its bid dated..... *[insert (by issuing agency) date]* (hereinafter called "the Bid") for the execution of ..... *[insert name of Contract]*

Furthermore, we understand that, according to the conditions, Bids must be supported by a Bid Guarantee.

At the request of the Bidder, we ..... *[insert name of issuing agency]* hereby irrevocably undertake to pay you any sum or sums not exceeding in total an amount of ..... *[insert amount in words]* ( ..... *[amount in figures]* upon receipt by us of your first demand in writing accompanied by a written statement stating that the Bidder is in breach of its obligation(s) under the bid conditions, because the Bidder:

- a) has withdrawn its Bid during the period of bid validity specified; or
- b) does not accept the correction of errors in accordance with the Instructions to Bidders(hereinafter "the ITB") ; or
- c) having been notified of the acceptance of its Bid by the Employer during the period of bid validity, (i) fails or refuses to execute the Contract Form, if required, or (ii) fails or refuse to furnish the Performance Security, in accordance with the ITB.

This guarantee will remain in force up to ..... *(insert date as at Invitation For Bid)*

Consequently, any demand for payment under this Guarantee must be received by us at the office on or before that date.

.....  
*[signature(s) of authorized representative(s)]*



# **SECTION - 10**

## **VAT FORM**

## Value Added Tax

**Service: Construction of Livestock Shed for Faculty of Agriculture at Technology Premises,  
Eastern University, Sri Lanka.**

The bidder is required to show the total amount of V.A.T. for the bid, separately in the place shown below. The bidder is strictly **instructed not to include V.A.T. in his bid value.**

**Particulars to be furnished by the bidder :**

1. V.A.T. registration No of the bidder :	
2. V.A.T. amount for the bid :	

.....  
Signature of Bidder

Date : .....

# **SECTION 11**

## **CHECK LIST**

**CHECK LIST**

*(The Bidder are advised to fill the following Table)*

	ITEM	ITB CLAUSE	YES (TICK)	REFERENCE
<b>1.</b>	<b>FORM OF BID</b>			
	Addressed to the Employer?	<b>18</b>		
	Completed?	<b>18</b>		
	Signed?	<b>18</b>		
<b>2.</b>	<b>BID SECURITY</b>			
	Addressed to the Employer?	<b>16</b>		
	Format as required?	<b>16</b>		
	Issuing Agency as specified?	<b>16</b>		
	Amount as requested?	<b>16</b>		
	Validity Period?			
<b>3.</b>	<b>ICTAD/CIDA Registration</b>			
	Grade?	<b>04</b>		
	Validity Period?	<b>04</b>		
<b>4.</b>	<b>QUALIFICATION INFORMATION</b>			
	All relevant information completed and submitted?	<b>04</b>		
	signed?	<b>04</b>		
<b>5.</b>	<b>ADDENDUM</b>			
	Contents of the addendum (if any) taken in account?	<b>10</b>		
<b>6.</b>	<b>BID PACKAGE</b>			
	All the documents given in Clause 12 .1 in the Bidding Data enclosed in the original and copy?	<b>12</b>		
	ITB Clause 19 followed before Sealing the Bid Package?	<b>19</b>		