

IFB NO. EUSL/AHEAD/R2/NCB/LCS/22/11-RC



EASTERN UNIVERSITY, SRI LANKA

**ACCELERATING HIGHER EDUCATION EXPANSION AND DEVELOPMENT
OPERATION (AHEAD)**

PROCUREMENT OF GOODS

(NATIONAL COMPETITIVE BIDDING)

*Supply, Delivery, Installation, Maintenance, and
Commissioning of Goods for Movie Theatre*

THE DEADLINE FOR BID SUBMISSION: 19/09/2022

AT 14.00 HOURS (02.00PM)

SECTION I: INVITATION FOR BIDS



**OTS/AHEAD PROJECT
EASTERN UNIVERSITY, SRI LANKA (EUSL)**

Invitation for Bids (IFB)

Supply, Delivery, Installation, Maintenance, and Commissioning of Goods for Movie Theatre

Procurement No: **EUSL/AHEAD/R2/NCB/LCS/22/11-RC**

The Chairman / Project Procurement Committee on behalf of the OTS, AHEAD Operations, Eastern University, Sri Lanka now invites sealed bids from eligible and qualified bidders for the **Supply, Delivery, Installation, Maintenance, and Commissioning of Goods for Movie Theatre under the National Competitive Bidding method.**

Additional details are provided in the Bidding Documents uploaded at the www.esn.ac.lk webpage. Bidding documents can be obtained at the office of the OTS/AHEAD by submitting the non-refundable fee of **Rs. 5,000.00**. Those who are obtaining bidding documents from the University Website should submit the completed documents along with a Bank Draft drawn in favor of the **“AHEAD Project, Eastern University, Sri Lanka”** as non-refundable fee to the Bank of Ceylon **A/C No: 82845710**.

Interested eligible bidders may obtain further information from the Deputy Director, Procurement, OTS AHEAD Operations of EUSL & inspect the bidding documents up to **16/09/2022** from 09.00 hour to 15.00 hour on working days at OTS AHEAD Operations, EUSL, Vantharumoolai, Chenkalady. **Tel. 065 2059393**.

Bids in **Two** copies indicating in Original and Duplicate must be delivered to the address given below **on or before 14.00 hour on 19/09/2022**. Late bids will be rejected. Bids will be opened at 14.00 hour on the same day at the CQA Board Room of the Eastern University, Sri Lanka. **Bidders can quote both, Sri Lankan Rupees (LKR) or United State Dollars (USD)** (According to the letter from the Ministry of Education dated 06/06/2022, No: HR/ER/MOHE/GEN)

All bids must be accompanied by a Bid Security in favor of the Vice Chancellor, Eastern University, Sri Lanka. Value of the Bid Security as mentioned in the below table.

Items	Bid Security	Valid up to
Supply, Delivery, Installation, Maintenance, and Commissioning of Goods for Movie Theatre 5.1 surround sound system for Digital Cinema Theater with all accessories -1, Server with DCP (Digital Cinema Package) player-1, UPS 10KVA -1, Blue-ray player-1, Mounting rack for sound system equipment-1, Large venue DLP Multi-Media Projector in Movie Theatre-1, Supply and Installation of 26 x 14 feet Silver Screen with Screen Frame-1, Heavy duty 13 volts' square pin power extension codes-3, 1500VA Stabilizer-1	1% of the quoted price of the bidder	19-01-2023

The title of the bid should be clearly mentioned in the top left corner of the bid submission envelope as specified below.

Procurement No. **EUSL/AHEAD/R2/NCB/LCS /22/11-RC**

A pre-bid meeting with bidders who collect the bidding documents will be held on **12/09/2022 at 10:30 am** in the Department of Language and Communication Studies Trincomalee Campus, Eastern University, Sri Lanka, Konesapuri, Nilaveli. The decision of the Project Procurement Committee is final and conclusive.

Chairman
Project Procurement Committee,
Eastern University, Sri Lanka
Vantharumoolai
Chenkalady
28/08/2022

Section II. Bidding Data Sheet (BDS)

The following specific data for the goods to be procured shall complement, supplement, or amend the provisions in the Instructions to Bidders (ITB). Whenever there is a conflict, the provisions herein shall prevail over those in ITB.

[Instructions for completing the Bid Data Sheet are provided, as needed, in the notes in italics mentioned for the relevant ITB Clauses.]

ITB Clause Reference	A. General				
ITB 1.1	The Purchaser is ¹ : Eastern University, Sri Lanka (EUSL)				
ITB 1.1	<p>The name and identification number of the Contract are²:</p> <p style="text-align: center;">SUPPLY, DELIVERY, INSTALLATION, MAINTENANCE, AND COMMISSIONING OF GOODS FOR MOVIE THEATRE</p> <p style="text-align: center;">PROCUREMENT No.: EUSL/AHEAD/R2/NCB/LCS/22/11-RC</p> <p>The number, identification and names of the lots comprising this procurement are³:</p> <table border="1" style="margin-left: auto; margin-right: auto;"> <thead> <tr> <th style="text-align: center;">Lot No</th> <th style="text-align: center;">Type of Items</th> </tr> </thead> <tbody> <tr> <td style="text-align: center;">1</td> <td> <p>Goods for Movie Theatre</p> <p>5.1 surround sound system for Digital Cinema Theater with all accessories -1, Server with DCP (Digital Cinema Package) player-1, UPS 10KVA -1, Blue-ray player-1, Mounting rack for sound system equipment-1, Large venue DLP Multi-Media Projector in Movie Theatre-1, Supply and Installation of 26 x 14 feet Silver Screen with Screen Frame-1, Heavy duty 13 volts' square pin power extension codes-3, 1500VA Stabilizer-1</p> </td> </tr> </tbody> </table>	Lot No	Type of Items	1	<p>Goods for Movie Theatre</p> <p>5.1 surround sound system for Digital Cinema Theater with all accessories -1, Server with DCP (Digital Cinema Package) player-1, UPS 10KVA -1, Blue-ray player-1, Mounting rack for sound system equipment-1, Large venue DLP Multi-Media Projector in Movie Theatre-1, Supply and Installation of 26 x 14 feet Silver Screen with Screen Frame-1, Heavy duty 13 volts' square pin power extension codes-3, 1500VA Stabilizer-1</p>
Lot No	Type of Items				
1	<p>Goods for Movie Theatre</p> <p>5.1 surround sound system for Digital Cinema Theater with all accessories -1, Server with DCP (Digital Cinema Package) player-1, UPS 10KVA -1, Blue-ray player-1, Mounting rack for sound system equipment-1, Large venue DLP Multi-Media Projector in Movie Theatre-1, Supply and Installation of 26 x 14 feet Silver Screen with Screen Frame-1, Heavy duty 13 volts' square pin power extension codes-3, 1500VA Stabilizer-1</p>				
ITB 2.1	<p>The source of funding is⁴: Credit/Grant #:6026-LK/8743-LK</p> <p style="text-align: center;">ACCELERATING HIGHER EDUCATION EXPANSION AND DEVELOPMENT OPERATION (AHEAD)</p>				
ITB 4.4⁵	Foreign bidders are not allowed to participate in bidding.				

	B. Contents of Bidding Documents				
ITB 7.1	<p>For <u>Clarification of bid purposes</u> only, the Purchaser's address is:</p> <p style="text-align: center;">Deputy Director Procurement, OTS/AHEAD Project, OTS Office, Eastern University, Sri Lanka, Vantharumoolai, Chenkalady. Tel: 065-2059393 E-mail: ddp_ots@esn.ac.lk ots@esn.ac.lk</p>				
	C. Preparation of Bids				
ITB 11.1 (e)⁶	<p>The Bidder shall submit the following additional documents:</p> <p>Document to prove the Qualification requested in IFB.</p> <ol style="list-style-type: none"> 1. Certified copy of Business Registration 2. Copy of the Manufacturer Authorization Letter issued by the Manufacturer or Distributor's Authorization Letter 3. Evidence to prove last Five years' experience in supplying similar products 4. Copies of Audited Financial Statements for last Three (03) years. (2021/2020, 2020/2019, 2019/2018) 5. Average turnover for last three years should be equal or more than Rs. 60 Million. 				
ITB 14.3⁷	<p>The bidders may quote to Supply, Delivery, Installation, Maintenance, and Commissioning of Goods for Movie Theatre</p> <table border="1" data-bbox="432 1438 1481 1700"> <thead> <tr> <th data-bbox="432 1438 571 1480">Lot No</th> <th data-bbox="571 1438 1481 1480">Type of Items</th> </tr> </thead> <tbody> <tr> <td data-bbox="432 1480 571 1700" style="text-align: center;">1</td> <td data-bbox="571 1480 1481 1700"> <p>Goods for Movie Theatre</p> <p>5.1 surround sound system for Digital Cinema Theater with all accessories -1, Server with DCP (Digital Cinema Package) player-1, UPS 10KVA -1, Blue-ray player-1, Mounting rack for sound system equipment-1, Large venue DLP Multi-Media Projector in Movie Theatre-1, Supply and Installation of 26 x 14 feet Silver Screen with Screen Frame-1, Heavy duty 13 volts' square pin power extension codes-3, 1500VA Stabilizer-1</p> </td> </tr> </tbody> </table>	Lot No	Type of Items	1	<p>Goods for Movie Theatre</p> <p>5.1 surround sound system for Digital Cinema Theater with all accessories -1, Server with DCP (Digital Cinema Package) player-1, UPS 10KVA -1, Blue-ray player-1, Mounting rack for sound system equipment-1, Large venue DLP Multi-Media Projector in Movie Theatre-1, Supply and Installation of 26 x 14 feet Silver Screen with Screen Frame-1, Heavy duty 13 volts' square pin power extension codes-3, 1500VA Stabilizer-1</p>
Lot No	Type of Items				
1	<p>Goods for Movie Theatre</p> <p>5.1 surround sound system for Digital Cinema Theater with all accessories -1, Server with DCP (Digital Cinema Package) player-1, UPS 10KVA -1, Blue-ray player-1, Mounting rack for sound system equipment-1, Large venue DLP Multi-Media Projector in Movie Theatre-1, Supply and Installation of 26 x 14 feet Silver Screen with Screen Frame-1, Heavy duty 13 volts' square pin power extension codes-3, 1500VA Stabilizer-1</p>				
ITB 15.1⁸	<p>The Bidder shall quote: Sri Lankan Rupees (LKR) or United State Dollars (USD) only.</p>				
ITB 18.1 (b)	<p>After-sales service is: Required</p>				

	Bidders are required to provide; (i) “after sales service” at least for a period of 05 years, after the warranty period.								
ITB 19.1⁹	The bid shall be valid until. 19-12-2022								
ITB 20.1	Bid shall include a Bid Security issued by a commercial bank registered in Sri Lanka. Form of bid security is given in Section IV.								
ITB 20.2¹⁰	The amount of the Bid Security shall be: <table border="1" data-bbox="453 613 1461 837"> <thead> <tr> <th>Lot No</th> <th>Type of Items</th> <th>Bid Security</th> <th>Valid up to</th> </tr> </thead> <tbody> <tr> <td>1</td> <td>Supply, Delivery, Installation, Maintenance, and Commissioning of Goods for Movie Theatre</td> <td>1% of the quoted price of the bidders</td> <td>19-01-2023</td> </tr> </tbody> </table>	Lot No	Type of Items	Bid Security	Valid up to	1	Supply, Delivery, Installation, Maintenance, and Commissioning of Goods for Movie Theatre	1% of the quoted price of the bidders	19-01-2023
Lot No	Type of Items	Bid Security	Valid up to						
1	Supply, Delivery, Installation, Maintenance, and Commissioning of Goods for Movie Theatre	1% of the quoted price of the bidders	19-01-2023						
	D. Submission and Opening of Bids								
ITB 22.2 (c)	The inner and outer envelopes shall bear the following identification marks: “ SUPPLY, DELIVERY, INSTALLATION, MAINTENANCE, AND COMMISSIONING OF GOODS FOR MOVIE THEATRE ”								
ITB 23.1	For bid submission purposes, the Purchaser’s address is: <p style="text-align: center;">Deputy Director/Procurement, OTS/AHEAD Project, Office of the Registrar, Senate Building, Eastern University, Sri Lanka, Vantharumoolai, Chenkalady Tp. No.: 0652059393</p> The deadline for the submission of bids is: Date: 19/09/2022 Time: 14.00 hours (02.00 p.m.)								
ITB 26.1	The bid opening shall take place at: <p style="text-align: center;">CQA Board Room Eastern University, Sri Lanka, Vantharumoolai, Chenkalady.</p> Date: 19/09/2022								

	Time: <i>Immediately after the bid closing time of 14.00 hour (02.00 p.m.)</i> of same date
	E. Evaluation and Comparison of Bids
ITB 34.1	Domestic preference <i>shall not</i> be a bid evaluation factor.
ITB 35.3(d)	The final price of the Price Schedule will be considered as the Bid Price (Subject to any adjustment if required)
ITB 35.4¹¹	The following factors and methodology will be used for evaluation: <ul style="list-style-type: none"> a. Fully compliance with technical specification & all other bidding conditions. b. Fully compliance to the mandatory item in the specification c. Certificate of Business Registration d. Authorization letter from the manufacturer or distributor's authorization letter e. Spares should be available at least for 5 years. f. Should supply with operating manual and service manual g. After sales services should be handled by local agents. h. Country of Origin should be stated i. Local usage of quoted brand/Model with the Customer's list. j. Quoted brand should be more than 5 years in the International Market. Bidder must be attached Evidence Document. k. Factors related to characteristics performance and terms and conditions of purchase of the good and relative services will be considered. l. Dollar rate will be converted in to LKR as of Bid opening date which is published by the Central Bank of Sri Lanka.
ITB 35.5	Purchaser shall <ul style="list-style-type: none"> a. Evaluate total items specified in ITB 14.3 as a single lot. b. Take into account the substantial, responsive, lowest-evaluated bidder.
ITB 43.1	Performance Bond should be submitted within Two week of Purchase order date, validity period of 120 Days (Beneficiary: The Vice Chancellor, Eastern University, Sri Lanka, Bond value: 10% of the total Purchase order Value, from Any bank registered under Central Bank of Sri Lanka
F. Others	
Pre bid meeting with bidders who collect the bidding documents will be held on 12/09/2022 at 10:30 AM at the Dept. of Languages and Communication Studies, Trincomalee Campus, Nilaveli, Konesapuri . Those who prefer to Join the pre bid meeting via Zoom, can obtain the link by sending an email to ots@esn.ac.lk before 12/09/2022 at 10:00 AM .	

Section IV. Bidding Forms

Table of Forms

Bid Submission Form	
Price Schedule:.....	
Bid Security (Guarantee)	
Bid-Securing Declaration	
Manufacturer's Authorization	

Bid Submission Form

[Note: the purchaser is required to fill the information marked as “” and delete this note prior to selling of the bidding document]*

[The Bidder shall fill in this Form in accordance with the instructions indicated No alterations to its format shall be permitted and no substitutions shall be accepted.]

Date: *[insert date (as day, month and year) of Bid Submission]*

No.: *[insert number of bidding process]*

To: *[* insert complete name of Purchaser]*

We, the undersigned, declare that:

- (a) We have examined and have no reservations to the Bidding Documents, including Addenda No.: *[insert the number and issuing date of each Addenda]*;
- (b) We offer to supply in conformity with the Bidding Documents and in accordance with the Delivery Schedules specified in the Schedule of Requirements the following Goods and Related Services *[* insert a brief description of the Goods and Related Services]*;
- (c) The total price of our Bid without VAT, including any discounts offered is: *[insert the total bid price in words and figures]*;
- (d) The total price of our Bid including VAT, and any discounts offered is: *[insert the total bid price in words and figures]*;
- (e) Our bid shall be valid for the period of time specified in ITB Sub-Clause 18.1, from the date fixed for the bid submission deadline in accordance with ITB Sub-Clause 23.1, and it shall remain binding upon us and may be accepted at any time before the expiration of that period;
- (f) If our bid is accepted, we commit to obtain a performance security in accordance with ITB Clause 43 and CC Clause 17 for the due performance of the Contract;
- (g) We have no conflict of interest in accordance with ITB Sub-Clause 4.3;
- (h) Our firm, its affiliates or subsidiaries—including any subcontractors or suppliers for any part of the contract—has not been declared blacklisted by the National Procurement Agency;
- (k) We understand that this bid, together with your written acceptance thereof included in your notification of award, shall constitute a binding contract between us, until a formal contract is prepared and executed.
- (l) We understand that you are not bound to accept the lowest evaluated bid or any other bid that you may receive.

Signed: *[insert signature of person whose name and capacity are shown]*
In the capacity of *[insert legal capacity of person signing the Bid Submission Form]*

Name: *[insert complete name of person signing the Bid Submission Form]*

Duly authorized to sign the bid for and on behalf of: *[insert complete name of Bidder]*

Dated on _____ day of _____, _____ *[insert date of signing]*

Price Schedule

*[The Bidder shall fill in these Price Schedule in accordance with the instructions indicated. The list of line items in column 1 of the **Price Schedules** shall coincide with the List of Goods and Related Services specified by the Purchaser in the Schedule of Requirements.]*

6.	Supply and Installation of Large venue DLP Multi Media Projector in Movie Theatre	01									
7.	Supply and Installation of 26 x 14 feet Silver Screen with Screen Frame	01									
8.	Heavy duty 13 volts' square pin power extension codes	03									
9.	1500VA Stabilizer	01									
Total											

***Allowed to apply USD price for imported items and LKR for local components. Evidence should be provided for imported items based on our request.**

Bid Guarantee

[Note: the purchaser is required to fill the information marked as "" and delete this note prior to selling of the bidding document]*

[this Bank Guarantee form shall be filled in accordance with the instructions indicated in brackets]

----- *[insert issuing agency's name, and address of issuing branch or office]* -----

***Beneficiary:** ----- *[name and address of Purchaser]*

Date: ----- *[insert (by issuing agency) date]*

BID GUARANTEE No.: ----- *[insert (by issuing agency) number]*

We have been informed that ----- *[insert (by issuing agency) name of the Bidder; if a joint venture, list complete legal names of partners]* (hereinafter called "the Bidder") has submitted to you its bid dated ----- *[insert (by issuing agency) date]* (hereinafter called "the Bid") for the supply of *[insert name of Supplier]* under Invitation for Bids No. ----- *[insert IFB number]* ("the IFB").

Furthermore, we understand that, according to your conditions, Bids must be supported by a Bid Guarantee.

At the request of the Bidder, we ----- *[insert name of issuing agency]* hereby irrevocably undertake to pay you any sum or sums not exceeding in total an amount of ---- *[insert amount in figures]* ----- *[insert amount in words]*) upon receipt by us of your first demand in writing accompanied by a written statement stating that the Bidder is in breach of its obligation(s) under the bid conditions, because the Bidder:

- (a) has withdrawn its Bid during the period of bid validity specified; or
- (b) does not accept the correction of errors in accordance with the Instructions to Bidders (hereinafter "the ITB"); or
- (c) having been notified of the acceptance of its Bid by the Purchaser during the period of bid validity, (i) fails or refuses to execute the Contract Form, if required, or (ii) fails or refuses to furnish the Performance Security, in accordance with the ITB.

This Guarantee shall expire: (a) if the Bidder is the successful bidder, upon our receipt of copies of the Contract signed by the Bidder and of the Performance Security issued to you by the Bidder; or (b) if the Bidder is not the successful bidder, upon the earlier of (i) our receipt of a copy of your notification to the Bidder that the Bidder was unsuccessful, otherwise it will remain in force up to ----- *(insert date)*

Consequently, any demand for payment under this Guarantee must be received by us at the office on or before that date. _____

[signature(s) of authorized representative(s)]

Bid-Securing Declaration

[Note: the purchaser is required to fill the information marked as “” and delete this note prior to selling of the bidding document]*

*[The **Bidder** shall fill in this form in accordance with the instructions indicated in brackets]*

Date: -----*[insert date by bidder]*

*Name of contract -- *[insert name]*

Contract Identification N^o: -----[insert number]*

*Invitation for Bid No.: ----- *insert number]*

*To: Vice Chancellor, EUSL

We, the undersigned, declare that:

1. We understand that, according to instructions to bidders (hereinafter “the ITB”), bids must be supported by a bid-securing declaration;
2. We accept that we shall be suspended from being eligible for contract award in any contract where bids have being invited by any of the Procuring Entity as defined in the Procurement Guidelines published by National Procurement Agency of Sri Lanka, for the period of time of *three years* starting on *the latest date set for closing of bids of this bid*, if we:
 - (a) withdraw our Bid during the period of bid validity period specified; or
 - (b) do not accept the correction of errors in accordance with the Instructions to Bidders of the Bidding Documents; or
 - (c) having been notified of the acceptance of our Bid by you, during the period of bid validity, (i) fail or refuse to execute the Contract Form, if required, or (ii) fail or refuse to furnish the performance security, in accordance with the ITB.
3. We understand this bid securing shall expire if we are not the successful bidder, upon the earlier of (i) our receipt of a copy of your notification to the Bidder that the bidder was unsuccessful; or (ii) twenty-eight days after the expiration of our bid.
4. We understand that if we are a JV, the Bid Securing Declaration must be in the name of the JV that submits the bid. If the JV has not been legally constituted at the time of bidding, the Bid Securing Declaration shall be in the names of all future partners as named in the letter of intent.

Signed *[insert signature(s) of authorized representative]* In the Capacity of *[insert title]*

Name *[insert printed or typed name]*

Duly authorized to sign the bid for and on behalf of *[insert authorizing entity]*

Dated on *[insert day]* day of *[insert month]*, *[insert year]*

Manufacturer's Authorization

[The Bidder shall require the Manufacturer to fill in this Form in accordance with the instructions indicated. This letter of authorization should be on the letterhead of the Manufacturer and should be signed by a person with the proper authority to sign documents that are binding on the Manufacturer. The Bidder shall include it in its bid, if so, indicated in the BDS.]

Date: *[insert date (as day, month and year) of Bid Submission]*
No.: *[insert number of bidding process]*

To: *[insert complete name of Purchaser]*

WHEREAS

We *[insert complete name of Manufacturer]*, who are official manufacturers of *[insert type of goods manufactured]*, having factories at *[insert full address of Manufacturer's factories]*, do hereby authorize *[insert complete name of Bidder]* to submit a bid the purpose of which is to provide the following Goods, manufactured by us *[insert name and or brief description of the Goods]*, and to subsequently negotiate and sign the Contract.

We hereby extend our full guarantee and warranty in accordance with Clause 27 of the Conditions of Contract, with respect to the Goods offered by the above firm.

Signed: *[insert signature(s) of authorized representative(s) of the Manufacturer]*

Name: *[insert complete name(s) of authorized representative(s) of the Manufacturer]*

Title: *[insert title]*

Duly authorized to sign this Authorization on behalf of: *[insert complete name of Bidder]*

Dated on _____ day of _____, _____ *[insert date of signing]*

Section V. Schedule of Requirements

Contents

1. List of Goods and Delivery Schedule
2. List of Related Services and Completion Schedule
3. Technical Specifications
- 4.. Drawings
5. Inspections and Tests

1. List of Goods and Delivery Schedule

[The Purchaser shall fill in this table, with the exception of the column “Bidder’s offered Delivery date” to be filled by the Bidder]

Line Item N°	Description of Goods	Quantity	unit	Final (Project Site) Destination as specified in BDS	Delivery Date ¹		
					Earliest Delivery Date	Latest Delivery Date	Bidder’s offered Delivery date [to be provided by the bidder- [insert the number of days following the date of effectiveness the Contract]]
1.	Supply, Delivery and Installation of 5.1 surround sound system for Digital Cinema Theater with all accessories	01	No		On or before 30 days from the date of purchase order	On or before 60 days from the date of purchase order	
2.	Server with DCP (Digital Cinema Package) player with life time license.	01	No				
3.	UPS 10KVA	01	No				
4.	Blue ray player	01	No				

¹ applicable only if delivery is considered for evaluation. If not only one column “Delivery Date” duly filled by the Purchaser is required

5.	Mounting rack for sound system equipment	01	<i>No</i>				
6.	Supply and Installation of Large venue DLP Multi Media Projector in Movie Theatre	01	<i>No</i>		<i>On or before 30 days from the date of purchase order</i>	On or before 60 days from the date of purchase order	
7.	Supply and Installation of 26 x 14 feet Silver Screen with Screen Frame	01	<i>No</i>				
8.	Heavy duty 13 volts' square pin power extension codes	03	<i>No</i>				
9.	1500VA Stabilizer	01	<i>No</i>				

2. List of Related Services and Completion Schedule

[This table shall be filled in by the Purchaser. The Required Completion Dates should be realistic, and consistent with the required Goods Delivery Dates]

Service	Description of Service	Quantity¹	Unit	Place where Services shall be performed	Final Completion Date(s) of Services
<i>[insert Service No]</i>	<i>[insert description of Related Services]</i>	<i>[insert quantity of items to be supplied]</i>	<i>[insert unit for the items]</i>	<i>[insert name of the Place]</i>	<i>[insert required Completion Date(s)]</i>
1.	Supply, Delivery and Installation of 5.1 surround sound system for Digital Cinema Theater with all accessories	01	No	Department of Language and Communication Studies Trincomalee Campus, Eastern University, Sri Lanka, Konesapuri, Nilaveli	
2.	Server with DCP (Digital Cinema Package) player with life time license.	01	No		
3.	UPS 10KVA	01	No		
4.	Blue ray player	01	No		
5.	Mounting rack for sound system equipment	01	No		

6.	Supply and Installation of Large venue DLP Multi Media Projector in Movie Theatre	01	No	Department of Language and Communication Studies Trincomalee Campus, Eastern University, Sri Lanka, Konesapuri, Nilaveli	
7.	Supply and Installation of 26 x 14 feet Silver Screen with Screen Frame	01	No		
8.	Heavy duty 13 volts' square pin power extension codes	03	Nos		
9.	1500VA Stabilizer	01	No		

03. TECHNICAL SPECIFICATIONS

[The Technical specifications may be provided in the following format. The bidder shall fill the columns 6 and 7. Bidder's failure to provide the information requested in the columns 6 and 7 may be a reason for the rejection of the bid. If any discrepancy is observed between the information provided by the bidder in the columns 6 and 7 and the other technical information attached to the bid, the information provided herein shall take precedence.]

Section IV: Technical Specification & Compliance

Specification for Cinema Solution System						
	DESCRIPTION	MINIMUM REQUIREMENTS	QTY	CONFIRMITY TO SPECIFICATION		REMARKS
				Yes	No	
	Required Item Specification given, solution should provide by supplier as design and built solution. All the equipment should comply with given specification.					
1	Supply, Delivery and Installation of 5.1 surround sound system for Digital Cinema Theater solution with all accessories;					
1.1	Screen Channel Loudspeaker 3 Way Array Loudspeaker (with Accessories) – 03Nos					
	Make	Please Specify				
	Model	Please Specify				
	Country of Origin	Please Specify				
	Country of Manufacturer	Please Specify				

Nominal Coverage (-6 dB)	90° horizontal x 30°			
Frequency Response1 (-6 dB)	30 Hz- 20 kHz			
Frequency Range1 (-10 dB)	32 Hz- 20 kHz			
Crossover Frequencies (passive)	400 Hz & 2000 Hz			
Crossover Frequencies (bi-amp)	500 Hz active, 24 dB /octave LF to mid-high,			
Sensitivity (1 watt / 1 meter, passive mode)	100 dB SPL			
Calculated Maximum Output (passive mode)	125 dB continuous, 130 dB peak SPL at 1 m			
LF Enclosure:				
Impedance	4 ohms (4Ω)			
Sensitivity 1 watt/1 meter, half space	100 dB or better			
Maximum Input Power	500 W continuous or better			
Maximum Recommended Amplifier Power	1000 W continuous or better			
Recommended Processing	Subsonic filter below 30 Hz, >18 dB per octave			
Connectors	Barrier strip screw terminals accept up to #10 AWG stranded wire			
Transducers	Two 15-inch high efficiency, extended bass			

	Enclosure	Ported enclosure with symmetrical port design, tuned to 40 Hz, constructed of MDF and heavily braced			
	HF Enclosure:				
	Impedance	8 ohms (8Ω)			
	Sensitivity 1 watt/1 meter, half space	96 dB			
	Maximum Input Power	80 W continuous or better			
	Maximum Recommended Amplifier Power	320 W continuous or better			
	Recommended Processing	4th-order LR crossover at 500 Hz			
	Connectors	Factory installed NL4 plug for connection to input terminal plate			
	Transducers	6.5-inch high efficiency mid-range, 1-inch exit, 1.4-inch diaphragm compression driver			
	Enclosure	Tilt/Pan Bracket -20 to +10° vertical tilt ± 15° horizontal pan			
	Warranty	3 Years or Better (Please Specify)			
1.2	Dual 18" (inch) Cinema Subwoofer (With Accessories) -01 Nos				

Make	Please Specify
Model	Please Specify
Country of Origin	Please Specify
Country of Manufacturer	Please Specify
Frequency Range1 (-10dB)	20 Hz to 150 Hz
Rated Noise Power (Voltage)	1100 W or better
Sensitivity	100 dB or better
Maximum Continuous SPL	130 dB or better
Maximum Peak SPL	130 dB or better
Rated Impedance	4 ohms (4Ω)
Recommended Amplifier Power	2200 Watts
Transducer	Two 18-inch woofers, 4-inch. voice coils
Enclosure Details	
Input Connectors	4-position barrier strip
Enclosure Material	MDF, 19 mm or better
Installation	Should require less than 17" inches behind screen
Warranty	3 Years or Better (Please Specify)

1.3

Cinema Surround Speaker (With Accessories & Brackets)	
Make	Please Specify
Model	Please Specify
Country of Origin	Please Specify
Country of Manufacturer	Please Specify

Features	Should have Ten digital inputs for 5.1 and 7.1 soundtracks and HI/VI or better			
	Dolby Digital or better			
	Should be able to Control and monitoring via Ethernet including full SNMP support			
	Should be able to Serial automation control via RS-232			
	Should be able to provide Analog Inputs for film processors, non-sync and Mic/Line or better			
	Should have Master volume and full 1/3 Octave Graphic EQ on all channels and no need for the subwoofer			
	Should be able to Booth Monitor loudspeaker and headphone jack			
	Should be able to Digital Loudspeaker Crossovers — three passive or bi-amp screen channels or better			
	Should be able to Bypass mode routes audio around failed components to insure that the Event/ Show will goes on without any interruptions			
Front Panel Controls and Indicators				

	and LIMIT LED Meters • HOME, ENTER, EXIT, GAIN Navigation Buttons • Control Knob			
Input Connectors	3-pin Euroblock x 4 nos			
Output Connectors	2-pin Euroblock Speaker x 4 nos			
Power Specifications				
4 Independent Channels A, B, C, D	@ 8Ω : Peak 900W, Continuous 625W @ 4Ω : Peak 1400W, Continuous 625W @ 2Ω : Peak 1200W, Continuous 625W or please specify			
2 Channel BTL Bridged A+B or C+D Doubles Voltage	@ 8Ω : Peak 2400W, Continuous 1250W or please specify			
2 Channel Parallel AB or CD Doubles Current	@ 8Ω : Peak 1200W, Continuous 1150W @ 4Ω : Peak 2000W, Continuous 1250W @ 2Ω : Peak 2500W, Continuous 1250W or please specify			
1 Channel 3CH Parallel ABC Triples Current	@ 8Ω : Peak 1400W, Continuous 1150W @ 4Ω : Peak 2400W, Continuous 2000W			

	@ 2Ω : Peak 3500W, Continuous 2500W or please specify				
1 Channel Bridged/Parallel AB+CD Doubles Current and Voltage	@ 8Ω : Peak 3500W, Continuous 3000W @ 4Ω : Peak 5000W, Continuous 2500W or please specify				
1 Channel 4CH Parallel ABCD Quadruples Current	@ 8Ω : Peak 1400W, Continuous 1150W @ 4Ω : Peak 3000W, Continuous 2500W @ 2Ω : Peak 5000W, Continuous 2500W or please specify				
Other Features	Should have 20 Factory Preset configurations that can be modified and stored in the 50 User Presets or more				
	Should have the Full function onboard loudspeaker processing DSP with Crossover and Parametric EQ Filters, Limiting and Alignment Delay eliminate the need for outboard loudspeaker processors				

	Should have the Flexible Amplifier Summing Technology™ (FAST) drives most any loudspeaker system or configuration by distributing total amplifier power across one, two, three or all four channels				
	Should have an Integrated front panel with channel Select and Mute buttons, Input and Output LED Metering, 400x240 LCD, intuitive navigation buttons, LED power button and indicator, and cast aluminum handles				
Warranty	3 Years or Better (Please Specify)				
Bidder can decide the quantity of the amplifiers based on the capacity and requirement.					
2 Channel Professional Power Amplifier					
Make	Please Specify				
Model	Please Specify				
Country of Origin	Please Specify				
Country of Manufacturer	Please Specify				

	<p>Output Connectors (each channel)</p>	<p>NL4, binding posts NL4 pinout: • Channel A on 1+, 1-; Channel B on 2+, 2- •Channel B on 1+, 1-</p>				
	<p>Amplifier and Load Protection</p>	<p>Short circuit, open circuit, thermal, RF protection Load protected against DC faults</p>				
	<p>Front Panel Controls and Indicators</p>	<p>2 × Rotary Encoders 3 × Operational buttons (HOME, ENTER, EXIT) 2 × Green Signal LEDs indicate signal presence 2 × Red A/D Clip LEDs indicate input over-drive and/or amplifier current clipping Blue Power LED ring indicates AC on 2.12-inch × 1.0-inch, 256 × 128 pixel LCD</p>				

	<p>DSP Functions</p>	<p>High-pass filter, 4th-order Linkwitz-Riley, adjustable frequency 20 Hz to 4 kHz Low-pass filter, 4th-order Linkwitz-Riley, adjustable frequency 60 Hz to 4 kHz 4-band parametric EQ with variable frequency, gain, and bandwidth Peak limiter with power, aggressiveness, and impedance selection Delay 50 msec max.</p>				
	<p>Other Features</p>	<p>Should have the Digital limiting automatically protects the amplifier from damage due to temperature rise or overdrive</p>				

	Digital Masking and Scaling			
	DCP and MXF Structure inspection DCP asset hash check			
	Warranty	3 Years or Better (Please Specify)		
	License required for life time			
3	10KVA-UPS			
	Make	Please Specify		
	Model	Please Specify		
	Country of Origin	Please Specify		
	Country of Manufacturer	Please Specify		
	Rated Power	10KVA/8KW		
	Input			
	Normal Voltage Range	220VAC		
	Voltage Range	120-275VAC		
	Frequency Range	46 - 54Hz		
	Power Factor	0.99		
	Connector	Harwired		
	Output			
	Voltage	230VAC ± 1%		
	Frequency	50Hz ± 0.1% (Battery Mode)		

		Level, UPS Power, Load Percent, Synchron Case, Communication systems fault info.			
	LED	Load on Bypass, Load on UPS, Alarm and operation by battery leds			
	Bypass	Alarm beeps every two minutes			
	Battery Discharge	Alarm beeps every four seconds, every second if battery low			
	Overload	Alarm Beeps two times for every second			
	Fault	Alarm beeps continuously			
	Acoustic Noise	55db			
	Warranty	3 Years or Better (Please Specify)			
4	Blueray Player				
	Make	Please Specify			
	Model	Please Specify			
	Country of Origin	Please Specify			
	Country of Manufacturer	Please Specify			

Playback Capability

DISC
BD-ROM/BD-R (DL)/BD-RE (DL)/BD-R LTH, CD (CD-DA), CD-R / -RW, DVD+R, DVD+R Double Layer, DVD+RW, DVD-Audio, DVD-R, DVD-R Dual Layer, DVD-RW, DVD-Video, SA-CD (SA-CD / CD) Playback, Stereoscopic 3D (profile 5), Ultra HD Blu-ray

VIDEO FORMAT
AVCHD Disc Format, Motion JPEG (.mov, .avi), MPEG-1 Video / PS (.mpg .MPEG, .mkv) .VOB, .VRO, MPEG-2 Video / PS, TS (.mpg.MPEG, .m2ts, .mts, .mkv) .VOB, .VRO, MPEG-4 / AVC (.mov, 3gp, .3g2, .3gpp, .3gpp2, .flv), MPEG-4

		<p>AVC (.mkv, .mp4, .m4v, .m2ts, .mts), VC1 (.m2ts, .mts, .mkv), WMV9 (.wmv, .asf, .mkv), Xvid (.avi, .mkv)</p>				
		<p>AUDIO FORMAT AAC (.AAC, .mka), AIFF (.aiff, .aif), ALAC (.m4a), Dolby Digital (.ac3, .mka), DSD - DSDIFF / DSD (.dff, .dsf), FLAC (.flac, .fla), HEAAC v.1 / v.2 / level2, LP cm (.mka), Vorbis, WMA10 Pro, WMA9 Standard (.WMA)</p>				
		<p>PHOTO FORMAT BMP (.bmp), GIF (.gif), JPEG (.jpg, .jpeg), MPO MPF 3D (.mpo), PNG (.png)</p>				
	<p>Picture and Audio Features</p>	<p>PICTURE FEATURE 24p True Cinema, , HDR → SDR converter, Deep colour (12bit), 4K Upscale (60p) or better</p>				
		<p>Should have CERTIFIED HI-RES AUDIO</p>				

		Should be compatible for Dolby Atmos / Dolby True HD decoding (7.1Ch)			
		Should be DTS:X(bitstream out)/DTS decoding (7.1ch)			
		Should have DSEE-HX			
		Should have Bluetooth TX, LDAC			
	Network	WI-FI® BUILT IN (2.4GHz, 5GHz)			
		should have DMP (Digital Media Player), DMR (Digital Media Renderer), and should be able to Screen mirroring (Wi-Fi Miracast)			
		Should have 3D Streaming, 4K streaming, Live Streaming			

	Terminals	INPUT AND OUTPUT Coaxial Audio Output (s): 1 (Rear), Ethernet Connection (s): 1 (Rear), HDMI Output (s): 2 (Rear), USB Input (s): 1 (Front)				
	Convenience Features	Auto Power Off (Auto Stand-by), BRAVIA Sync, Child Lock, Parental Control				
		Should come with a Remote Controller				
		Warranty	3 Years or Better (Please Specify)			
5	Mounting rack for equipment	19" U 42 open wall rack				
6	Supply and Installation of Large Venue DLP Multi Media Projector in Movie Theatre					
	Make	Please Specify				
	Model	Please Specify				

	Product weight	Please Specify			
	Noise Level	Normal: 39 dB (A) - Economy: 31 dB (A) (4K enhancement OFF)			
	Zooming Lens	Throw distance 13 meters (Bidders can visit the site and propose accordingly)			
	Warranty	3 Years or Better (Please Specify)			
7	Supply and Installation of 26 x 14 feet Silver Screen with Screen Frame				
	Size	26 x 14			
	Type	Silver (3D) Prism			
	Gain	2.4 or Higher			
	Material	SLS Standard GI pipe 1 4/1 2mm			
	Warranty	3 Years or Better (Please Specify)			
8	Heavy duty 13 volts' square pin power extension codes	5 way or higher			
9	1500VA Stabilizer				
	Power:	1500VA			
	Input voltage:	150-260V (1P) /120V- 260V			
	Output voltage:	220V			

Stabilization accuracy:	220V±3%			
Frequency:	50Hz/60Hz			
Overload power factor:	0.8			
Efficiency:	≥90%			
Voltage over voltage:	246±4V			
Installation Required				
All the materials used for installation should be durable, long lasting and quality products.				
Other relevant documents				
Manufacturer Authorization letter or Distributor Authorization letter should be attached for brand you quote.				
Catalogs or Manuals (English) should be attached				
Experience				
Vendors Should have more than five years' experience in the relevant field.				
Bidder's Eligibility Requirements				
Bidder should have well trained & qualified technical staff with service center.				
Bidder should provide at least 3 Nos of customer details (customer name, contact no, address, contact person).				
The bidder may require to make a presentation if needed.				
Drawings are attached for the reference.				

5. Inspections and Tests

The following inspections and tests shall be performed: *[insert list of inspections and tests if any]*

Section VII. Contract Data

The following Contract Data shall supplement and / or amend the Conditions of Contract (CC). Whenever there is a conflict, the provisions herein shall prevail over those in the CC.

CC 1.1(i)	The Purchaser is: The Vice-Chancellor, Eastern University, Sri Lanka
CC 1.1 (m)	The Project Site(s)/Final Destination(s) is/are: Trincomalee campus. Nilaveli Konesapuri
CC 8.1	For notices , the Purchaser's address shall be: Deputy Director/Procurement, OTS/AHEAD Project, Eastern University, Sri Lanka, Vantharumoolai, Chenkalady E-mail : ddp_ots@esn.ac.lk Tp. No : 0652059393
CC 12.1	Details of Shipping and other Documents to be furnished by the Supplier are required.
CC 15.1	The method and conditions of payment to be made to the Supplier under this Contract shall be as follows: A: For Goods offered within Sri Lanka Payment shall be made in Sri Lanka Rupees within thirty (30) days of presentation of claim supported by a certificate from the Purchaser declaring that the Goods have been delivered installed and properly commissioning with the appraisal report of end users that all other contracted Services have been performed.
CC 17.1	A Performance Security: should be submitted within Two week of PO date for validity period of 120 Days (Beneficiary: The Vice Chancellor, Eastern University, Sri Lanka, Bond value: 10% of the total PO Value, from Any bank registered in Sri Lanka.
CC 25.1	The inspections and tests shall be ¹³ : required on all component & Services includes use acceptance test at the premises of the EUSL.
CC 25.2	The Inspections and tests shall be conducted by a team appointed by the EUSL
CC 26.1	The liquidated damage shall be 1 % per week from the Contract Price
CC 26.1	The maximum amount of liquidated damages shall be 10 %

Check List

No	Required Specification	Bidder's Offer			
		Conformity		Page No	Remark
		Yes	No		
1	Company Profile				
2	Business Registration				
3	VAT Registration				
4	List of Clients				
5	Past experience in the field				
6	Manufacturer/ Distributor Authorization				
7	Bid Security				
8	Forms of Bids				
9	Price Schedule				
10	Tender Fee				
11	Financial Statement				
Status					

“Check list must be filled by the Bidder”

Annexure- Drawings

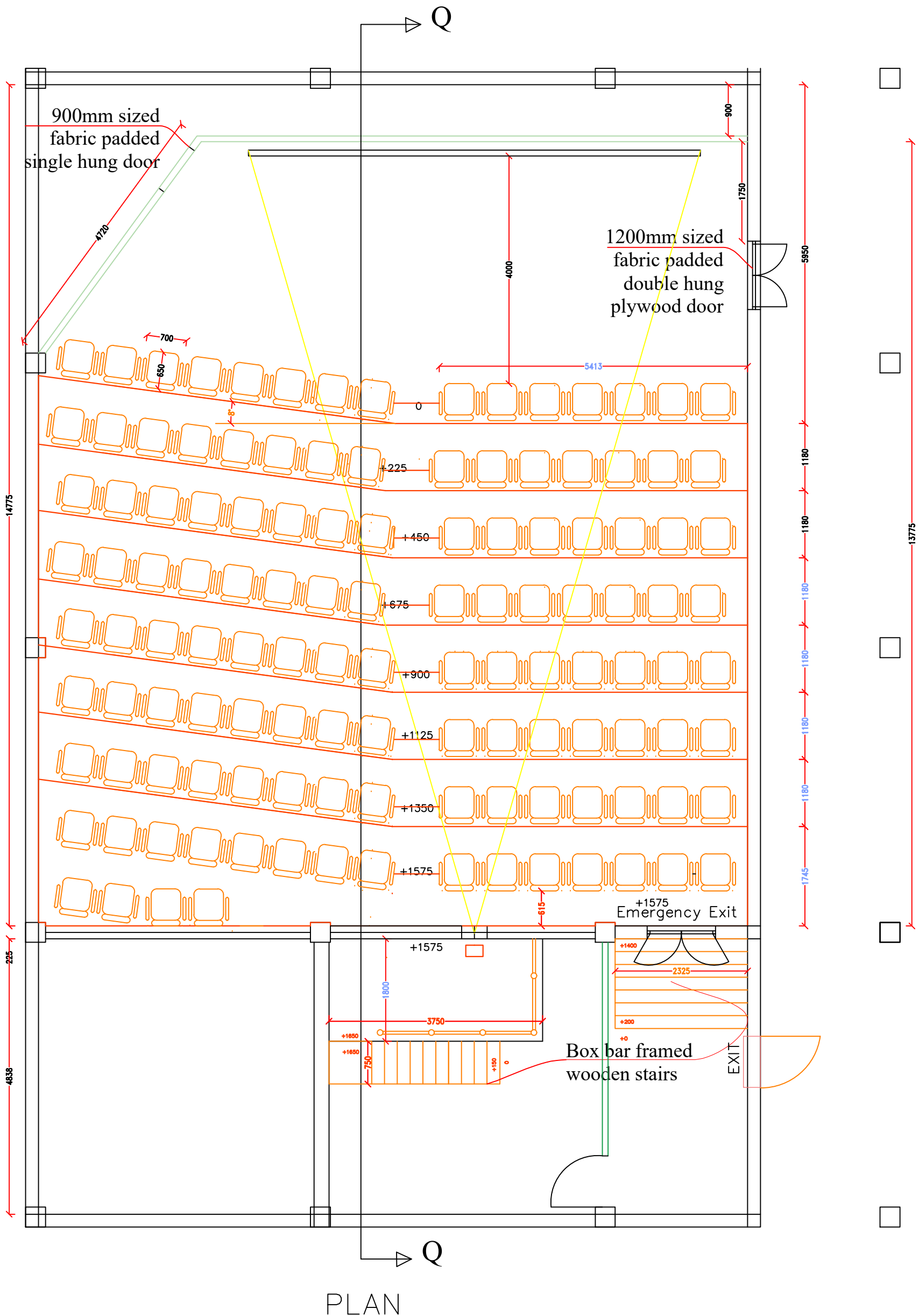

Project Name	Establishing a mini movie theatre by refurbishing existing lecture hall at Trincomalee Campus, EUSL					
Drawing title	Plan view of the proposed mini movie theatre					
Designed by	Drawn by	Checked by	Approved by	Drawing No:	Revision No	Date
				AHEAD/LCS/MT/plan		
						Scale
						Not in scale

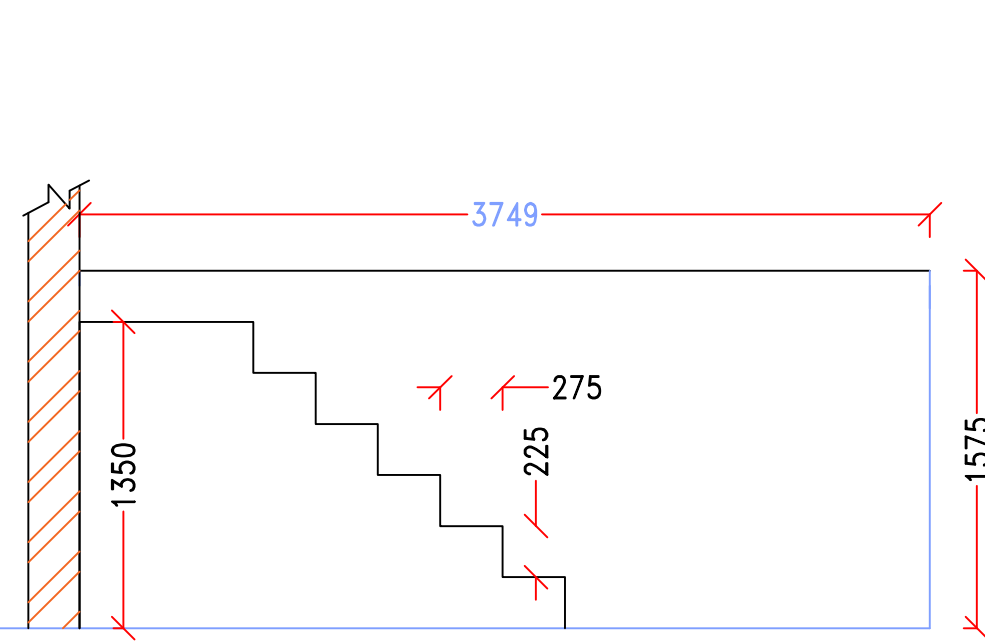
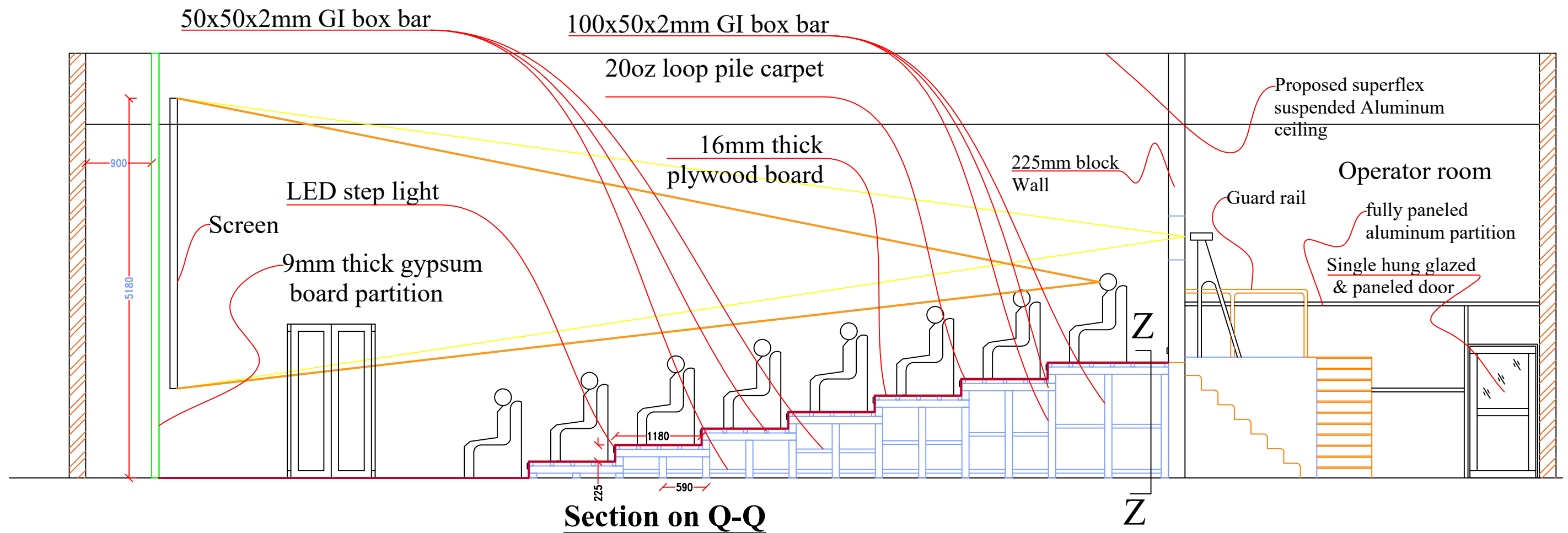

Elevation of projector platform

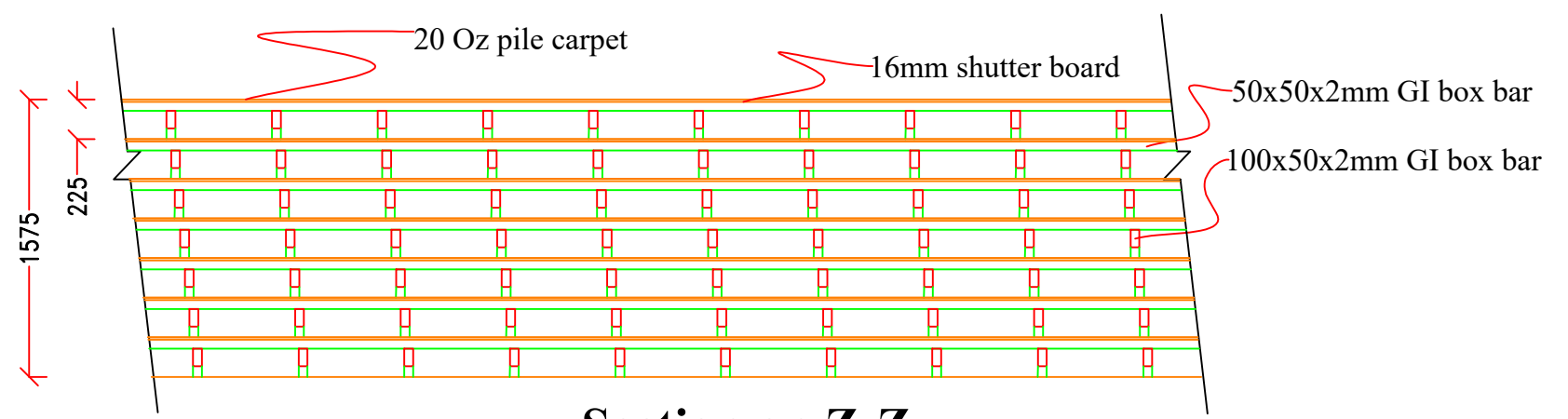

Section on Z-Z

Project Name	Establishing a mini movie theatre by refurbishing existing lecture hall at Trincomalee Campus, EUSL					
Drawing title	Section drawings of the proposed mini movie theatre					
Designed by	Drawn by	Checked by	Approved by	Drawing No:	Revision No	Date
				AHEAD/LCS/MT/plan		
						Scale
						Not in scale

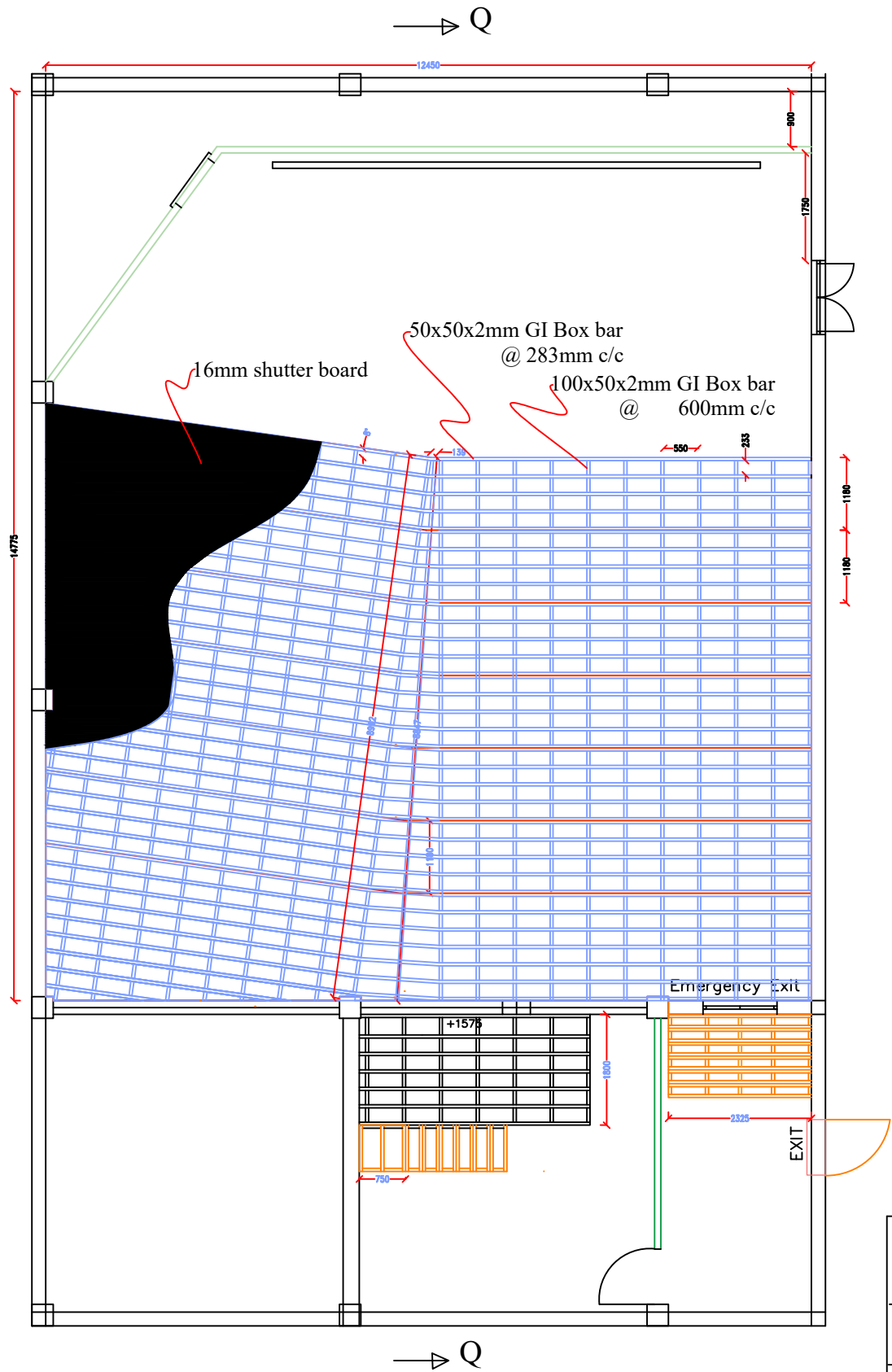

Details of box bar frame for seating arrangement

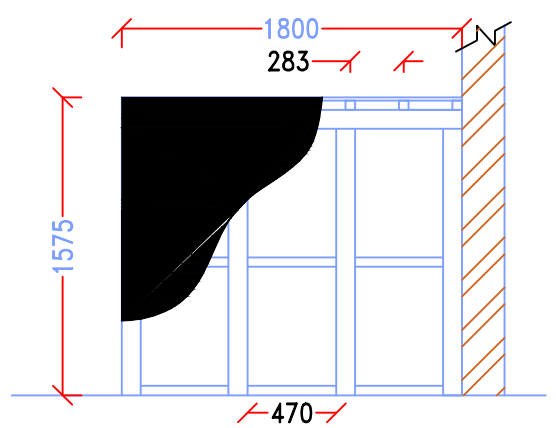

Details of projector operator's platform

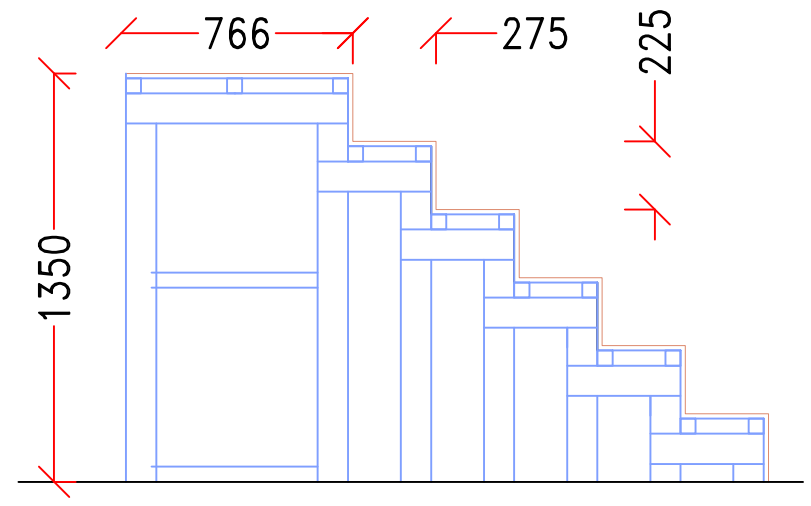
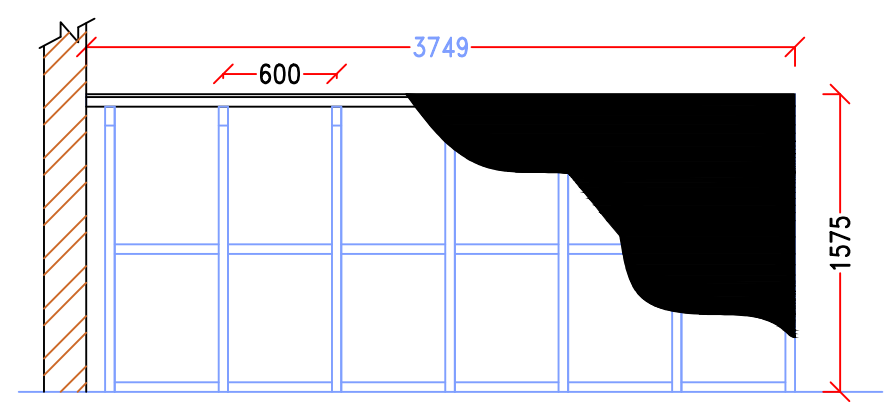

Details of box bar framed stair cases

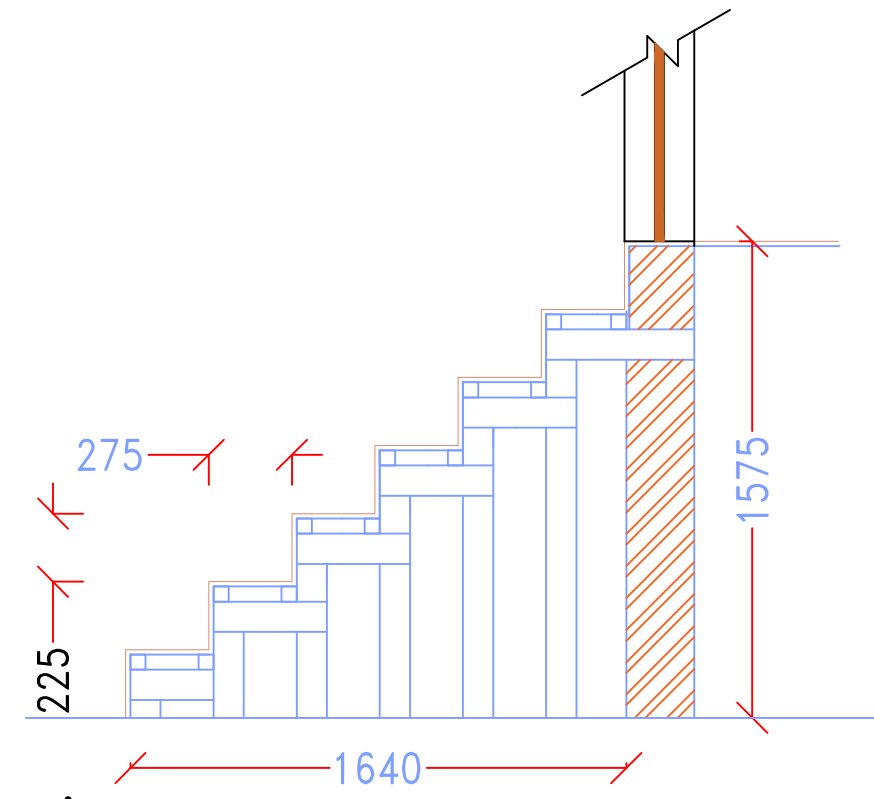

Project Name	Establishing a mini movie theatre by refurbishing existing lecture hall at Trincomalee Campus, EUSL					
Drawing title	Details of box bar frame work of the proposed mini movie theatre					
Designed by	Drawn by	Checked by	Approved by	Drawing No:	Revision No	Date
				AHEAD/LCS/MT/plan		21.05.2021
						Scale
						Not in scale