



# EASTERN UNIVERSITY, SRI LANKA

## PROCUREMENT DOCUMENT

FOR

**Re-Construction of Boundary Wall Girls Hostel Area in Eastern University, Sri Lanka, Vantharumoolai**

**Issued to** : .....

**Issued by** : .....

**Date** : .....

**Bid No.** : .....

**Non-refundable Fee Receipt No. & Date:** .....

---

**CONTENTS**

<b><u>NO</u></b>		<b><u>PAGE</u></b>
	<b>INVITATION FOR BIDS -</b>	<b>1</b>
	<b>VOLUME I</b>	
SECTION 1	INSTRUCTIONS TO BIDDERS	3
SECTION 2	STANDARD FORMS	5
SECTION 3	CONDITIONS OF CONTRACT	12
	<b>VOLUME II</b>	
SECTION 4	Non collusion Affidavit,FORM OF BID AND QUALIFICATION INFORMATION	14
SECTION 5	BIDDING DATA AND CONTRACT DATA	20
SECTION 6	SPECIFICATIONS	31
SECTION 7	BILL OF QUANTITIES	33
SECTION 8	STANDARD FORM [BID]	38
SECTION 9	VAT FORM	40
SECTION 10	DRAWING	42
SECTION 11	CHECK LIST	44



**Eastern University, Sri Lanka**  
**Invitation for Bids (IFB)**  
**National Competitive Method (NCB)**  
**Rehabilitation and Improvement of Building and other Structures at**  
**Eastern University, Sri Lanka**

The Chairman, Department Procurement Committee, on behalf of the Eastern University, Sri Lanka will receive sealed bids from interested eligible and qualified bidders for the works mentioned in the table given below and receiving will be closed at 10.30 a.m. on 11.06.2026 Procurement Documents shall be obtained from Deputy Registrar (Capital Works & Planning) in person or by sending a request to dr\_capitalworks@esn.ac.lk up to 3.00 p.m. on 10.06.2026. The non-refundable tender fee as mentioned in table below shall be credited to the Account No: 227100140000024 in the Peoples Bank in favour of “Bursar, Eastern University, Sri Lanka”.

Name of Work	Estimated Cost Excl. VAT (Rs)	Required ICTAD/CIDA Valid Grade and the Specialty	Bid validity period	Bid Security (Rs)	Bid Security valid up to	Non-refundable tender fee (Rs)
Renovation and Re-Construction of Boundary Wall (Old Premises) at Eastern University, Sri Lanka, Vantharumoolai.	12,379,797.07	C 07 or above Building	77 days	150,000.00	24.09.2026	4,000.00

- Bidding will be conducted through National Competitive Bidding Method (NCB).
- Bids shall be accompanied by a Bid Security which shall be;
  - in the format included in the Bidding document
  - in favour of **Vice Chancellor, Eastern University, Sri Lanka**
  - amount and validity period as mentioned above
  - issued by a commercial bank operating in Sri Lanka and approved by the Central Bank of Sri Lanka or Construction Guarantee Fund
- Sealed Bids shall be delivered to the address given below. The bids received after the closing time and date will be rejected.

Bids to be delivered to:

**The Registrar**  
**Office of the Registrar**  
**Eastern University, Sri Lanka**  
**Vantharumoolai, Chenkalady**

4. Bids will be opened immediately after the closing time at the above address.
5. Bidders or their authorized representatives are allowed to be present at the opening of Bids.
6. Interested bidders may obtain further information from Deputy Registrar (CW&P) on 0652240589, and Works Engineer on 0652240582 of Eastern University, Sri Lanka at Chenkalady during any working days from 9.00 hrs to 14.00 hrs.
7. Pre-Bid meeting will be held on 03.06.2026 10.00 am at the office of the Deputy Registrar /Capital Works and Planning of the Eastern University, Sri Lanka.

**The Chairman**

**Department Procurement Committee**

**Eastern University, Sri Lanka**

**Vantharumoolai**

**Chenkalady.**

**29.05.2026**

# **SECTION 1**

## **INSTRUCTIONS TO BIDDERS**

# SECTION 1

## INSTRUCTIONS TO BIDDERS

1. The Instructions to the Bidders for this work are contained in Section 01 of the Standard Bidding Document, “Procurement of Works”, ICTAD/CIDA Publication No. ICTAD/SBD/01, Second Edition – January 2007 and Addendum 1 and 2 published on October 2009 and February 2011 respectively. The Bidder may purchase this document from Institute for Construction Training And Development, No. 123, Wijerama Mawatha, “Sawsiripaya”, Colombo-07.

<p><i>Note:</i></p> <ol style="list-style-type: none"><li>1. <b>Instructions to Bidders shall be read in conjunction with Section 05 Bidding Data– Volume II.</b></li><li>2. <b>Instruction to Bidders will not be a part of the Contract and will cease to have effect once the Contract is signed.</b></li></ol>
--

# **SECTION 2**

## **STANDARD FORMS [CONTRACT]**

- 1. FORM OF LETTER OF ACCEPTANCE**
- 2. AGREEMENT**
- 3. FORM OF PERFORMANCE SECURITY**
- 4. FORM OF ADVANCE PAYMENT SECURITY**
- 5. FORM OF RETENTION MONEY GUARANTEE**

**Form of Letter of Acceptance**

.....[date]  
[LETTER HEADING PAPER OF THE PROCURING ENTITY]

To: ----- [name and address of the Contractor] -----

Name of the project and Contract No.

This is to notify you that your bid dated ----- [insert date] for the construction and remedying defects of the ----- [name of the Contract and identification number] for the Contract price of -----[name of currency]----- [amount in figures and words] as corrected in accordance with Instructions to Bidders and/ or modified by a Memorandum of Understanding, is hereby accepted.

You are hereby instructed to proceed with the execution of the said Works in accordance with the Contract documents.

The Commencement Date shall be: ..... (fill the date as per Clause 6.1 of Conditions of Contract).

The amount of Performance Security is : ..... (fill the amount as per Clause 4.4 of Conditions of Contract).

The Performance Security shall be submitted on or before ..... (fill the date as per Clause 4.4 of Conditions of Contract).

Authorized Signature:.....

Name and title of Signatory: .....

Name of Agency: .....

## ARTICLE OF AGREEMENT

This ARTICLES of Agreement, made the ..... day of ..... -.....-2026 between ..... holding the office of the Vice Chancellor of the Eastern University, Sri Lanka in the Government of the Democratic Socialist Republic of Sri Lanka (hereinafter called the "the Employer") for himself and his successors in the said office for the time being, acting for and on behalf of the DEMOCRATIC SOCIALIST REPUBLIC OF SRI LANKA (hereinafter sometimes referred to as the Republic of Sri Lanka) of the one part and ..... .. trading under the name, firm and style of **Messrs.** ..... a Company duly incorporated and having its registered office at .....(hereinafter designated "the Contractor" which expressions shall include his or their heirs, executors, administrators and legal representatives or where the context so admits, include its successors and permitted assigns) of the other part.

WHEREAS the Employer is desirous that the Contractor execute..... (hereinafter called "the Works") and the Employer has accepted the Bid by the Contractor for the execution and completion of such Works and the remedying of any defects therein.

NOW THIS AGREEMENT WITNESSETH as follows:

1. In this Agreement, words and expressions shall have the same meanings as are respectively assigned to them in the Conditions of Contract hereinafter referred to, and they shall be deemed to form and be read and construed as part of this Agreement.
2. In consideration of the payments to be made by the Employer to the Contractor as hereinafter mentioned, the Contractor hereby covenants with the Employer to execute and complete the Works and remedy any defects therein in conformity in all respects with the provisions of the Contract.

3. The Employer hereby covenants to pay the Contractor in consideration of the execution and completion of the Works and the remedying of defects wherein the Contract Price or such other sum as may become payable under the provisions of the Contract at the times and in the manner prescribed by the Contract.

IN WITNESS whereof the parties thereto have caused this Agreement to be executed the day and year aforementioned in accordance with laws of Sri Lanka.

.....

**Signature of the Vice Chancellor, Eastern University, Sri Lanka**

WITNESSES:

1. Signature:.....

2. Signature:.....

Designation:.....

Designation:.....

.....

**Signature of the Contractor/Director of the Company**

Name : .....

NIC No.....

**Common Seal**

WITNESSES:

1. Signature.....

2. Signature.....

NIC No.....

NIC No.....

Name & Address.....

Name & Address.....

.....

.....

.....

.....

***Form of Performance Security***  
**(Unconditional)**

**Issuing Agency:** .....  
*[Issuing Agency Name and Address of Issuing Branch or Office]*

**Beneficiary:** Vice Chancellor,  
Eastern University, Sri Lanka

**Date:** .....

**PERFORMANCE GUARANTEE No:** .....

We have been informed that ..... *[name of the Company]* (hereinafter called "the Contractor") has entered into Contract No. .... *[reference number of the contract]* with you, in the year ....., for the.....*[name of the Contract]* (hereinafter called "the Contract");

Furthermore, we understand that, according to the conditions of the Contract, a performance guarantee is required.

At the request of the Contractor, we ..... *[name of Agency]* hereby irrevocably undertake to pay you any sum or sums not exceeding in total an amount of ..... *[amount in words]* (.....) *[amount in figures]*, upon receipt by us of your first demand in writing accompanied by a written statement stating that the Contractor is in breach of its obligation(s) under the Contract, without your needing to prove or to show grounds for your demand or the sum specified therein.

This guarantee shall expire, no later than the ..... day of ..... 20..... *[insert date, 28 days beyond the intended completion Date]* and any demand for payment under it must be received by us at this office on or before that date.

.....  
*[signature(s)]*

## *Form of Advance Payment Security*

**Issuing Agency:** ..... [Name and Address of Agency, and Address of Issuing Branch or Office]

**Beneficiary:** Vice Chancellor,  
Eastern University, Sri Lanka

**Date:** .....

**ADVANCE PAYMENT GUARANTEE No:** .....

We have been informed that ..... [name of Contractor] (hereinafter called "the Contractor") has entered into Contract No. .... [reference number of the contract] with you, in the year ....., for the..... [name of the contract] (hereinafter called "the Contract");

Furthermore, we understand that, according to the conditions of the Contract, an advance payment in the sum ..... [amount in words] (.....) [amount in figures] is to be made against an advance payment guarantee.

At the request of the Contractor, we ..... [name of Issuing agency] hereby irrevocably undertake to pay you any sum or sums not exceeding in total an amount of ..... [amount in words] (.....) [amount in figures], upon receipt by us of your first demand in writing accompanied by a written statement stating that the Contractor is in breach of its obligation in repayment of the Advance payment under the Contract

The maximum amount of this guarantee shall be progressively reduced by the amount of the advance payment repaid by the Contractor.

This guarantee shall expire on ..... [insert date, 28 days beyond the Intended Completion Date]

Consequently, any demand for payment under this guarantee must be received by us at this office on or before that date.

.....  
[signature(s)]

## *Form of Retention Money Guarantee*

**Issuing Agency:** .....

-- [Issuing Agency's Name and Address of Issuing Branch or Office]

**Beneficiary:** Vice Chancellor,  
Eastern University, Sri Lanka

**Date:** .....

**RETENTION MONEY GUARANTEE No:** .....

We have been informed that ..... [name of Contractor] (hereinafter called "the Contractor") has entered into Contract No. .... [reference number of the contract] with you, in the year ....., for the execution of ..... [name of the Contract and brief descriptions of Works] (hereinafter called "the Contract");

Furthermore, we understand that, according to the conditions of the Contract, when the works have been taken over and the first half of the Retention Money has been certified for the payment, payment of the second half of the Retention Money may be made against a Retention Money guarantee.

At the request of the Contractor, we ..... [name of Agency] hereby irrevocably undertake to pay you any sum or sums not exceeding in total an amount of ..... [amount in words] (.....) [amount in figures], upon receipt by us of your first demand in writing accompanied by a written statement stating that the Contractor is in breach of its obligation under the Contract, because the contractor has not attended to the defects in accordance with the Contract.

This guarantee shall expire, at the latest, ..... [insert date, 28 Days after the end of the Defects Liability Period] Consequently, any demand for payment under this guarantee must be received by us at this office on or before that date.

.....  
[signature(s)]

**SECTION 3**  
**CONDITIONS OF CONTRACT**

---

## CONDITIONS OF CONTRACT

### PART I - GENERAL CONDITIONS OF CONTRACT

1. The General Conditions for this work are contained in Section 03 of the Standard Bidding Document, "Procurement of Works", ICTAD Publication No. ICTAD/SBD/01, Second Edition - January 2007 and Addendum 1 and 2 published on October 2009 and February 2011 responsively. The Bidder may purchase this document from Construction Training And Development, No. 123, Wijerama Mawatha, "Sawsiripaya",Colombo-07.

<p><b>Note:</b> Conditions of Contract shall be read in conjunction with Section 05 Contract Data in volume II, which shall take precedence over the Condition of Contract.</p>
---

# **SECTION 4**

## **NON-COLLUSION AFFIDAVIT, FORM OF BID AND QUALIFICATION INFORMATION**

**NON-COLLUSION AFFIDAVIT**

The undersigned bidder or agent, hereby solemnly, sincerely, and truly declares and affirms/makes an oath and states as follows;

- a) That he/she has not, nor has any other member, representative, or agent of the firm, company, corporation, or partnership representing him/her, entered into any combination, collusion, or similar agreement with any person in connection with the price to be bid;
- b) That he/she or anyone representing him/her has not taken any step whatsoever to prevent any person from bidding, nor to induce anyone to refrain from bidding; and
- c) That this bid is made without reference to any other bid and without any agreement, understanding, or combination with any other person in reference to this bid.

He/she further states that no person, firm, or corporation has received or will receive, directly or indirectly, any rebate, fee, gift, commission, or thing of value in connection with the submission of this bid.

The bidder accepts full responsibility for ensuring the absence of collusion and hereby pledges to abide by fair and ethical competition practices throughout the procurement process and fully comply with the applicable Procurement Guidelines.

I hereby affirm, under the penalties for perjury, that all statements made by me in this affidavit are true and correct.

.....  
Signature of the Declarant

The foregoing Affidavit having been duly read over and explained by me to the Affirmant above named and he/she having understood the contents therein and admitted to be correct, affirmed and set his/her signature hereto before me on this .... day of ... at ...  
BEFORE ME,

.....  
JUSTICE OF THE PEACE/COMMISSIONER OF OATHS

## FORM OF BID

**Name of the Contract:** Re-Construction of Boundary Wall Girls Hostel Area in Eastern University, Sri Lanka, Vantharumoolai.

**To: Vice Chancellor,  
Eastern University, Sri Lanka,**

Gentleman,

1. Having examined the Standard Bidding Document - Procurement of Works (ICTAD/SBD/01,-Second Edition - January 2007 and Addendum 1 and 2 published on October 2009 and February 2011 responsively) Specifications, Drawings and Bill of Quantities and Addenda, if any, for the execution of the above named Works, we the undersigned, offer to execute and complete such Works and remedy any defect therein in conformity with the aforesaid Conditions of Contract, Specifications, Drawings, Bill of Quantities and Addenda, if any, for the sum of Sri Lankan Rupees .....  
.....  
.....(Excluding VAT) (SLRs.....) or such other sums as may be ascertained in accordance with the said Conditions.
2. We acknowledge that the Contract Data forms part of our Bid.
3. We undertake, if our Bid is accepted, to commence the works as stipulated in the Contract Data, and to complete the whole of the Works comprised in the Contract within the time stated in the Contract Data.
4. We agree to abide by this Bid for the period of **77 days** from the date fixed for receiving or any extended period and it shall remain binding upon us and may be accepted at any time before the expiration of that period.
5. Unless and until a formal Agreement is prepared and executed this Bid, together with your written acceptance thereof, shall constitute a binding contract between us.
6. We accept/do not accept the Adjudicator
7. We understand that you are not bound to accept the lowest or any Bid you may receive.

Dated this ..... day of ..... Two Thousand and ..... in the capacity of .....(designation) duly authorised as – *sole proprietor/power of attorney holder* ( *Delete whichever is not applicable*) to sign tenders for and on behalf of .....

.....  
(IN BLOCK CAPITALS)

Signature : .....  
Name : .....  
Address : .....  
.....  
.....  
.....

Seal

Witnesses

1. Signature : .....  
Name : .....  
Address : .....  
.....  
.....  
.....

2. Signature: .....  
Name : .....  
Address: .....  
.....  
.....  
.....

## Qualification Information

*[To be completed by the Bidder and submitted with the Bid.]*

<b>ICTAD Registration:</b>	<b>Eligibility Requirement</b>	Attach copies of relevant pages from the registration book to confirm your details (attach as annex I).
Registration No		
Grade	<b>C 07 or above</b>	
Speciality	<b>Building Construction</b>	
Validity	<b>Valid at the time of closing of bids and also at the time of award.</b>	
<b>Blacklisted Contactors</b>	Have you been declared as a defaulted contractor by NPA or any other Agency? <b>(Yes/No)</b> If yes provide details (attach as annex II).	
<b>Construction Programme</b>	(attach as annex III)	
<b>Legal Status</b>	Status: Sole Proprietor <input type="checkbox"/> Partnership <input type="checkbox"/> Public Company <input type="checkbox"/> Private Company <input type="checkbox"/> Business Address : ..... ..... ..... Telephone Number : Land :.....Mobile..... Facsimile Number :..... E-mail Address :..... (Signatory of the bid should be duly authorized. Copy of the Board Resolution or power of Attorney for other than Sole Proprietor should be submitted along with the bid as annex IV)	
<b>Signatory of Bid</b>	Sole Proprietor <input type="checkbox"/> Power of Attorney holder <input type="checkbox"/>	
<b>Details of Annual Volume of the Construction works requested as in the Bidding Data Cl. 4.4;</b>	(attach copies of certificates of completion etc, and/or other financial statement or audited report by Chartered Accountant as annex VI)	
<b>Details of Construction works requested as in the Bidding Data Cl. 4.4;</b>	(attach copies of cliental certificates of completion etc, as annex VI)	

<b>Details of construction equipment proposed for the project.</b>	<i>(attach as annex VII)</i>												
<b>Qualification and experience of key staff required as in the Bidding data Cl. 4.4 (c)</b>	<table border="1"> <thead> <tr> <th><b>Eligibility Requirements</b></th> <th colspan="2"><b>Bidder's Qualification</b></th> </tr> <tr> <th>Category, Experience and Qualification</th> <th>Required Nos.</th> <th>Proposed by bidder (Name, experience and Qualification)</th> </tr> </thead> <tbody> <tr> <td>B.Sc. (Civil) Engineer experience in Building Construction - Part Time</td> <td>01</td> <td></td> </tr> <tr> <td>Technical Officer - NDT (Civil) or equivalent 5 years' experience in Building Construction - Full time</td> <td>01</td> <td></td> </tr> </tbody> </table>	<b>Eligibility Requirements</b>	<b>Bidder's Qualification</b>		Category, Experience and Qualification	Required Nos.	Proposed by bidder (Name, experience and Qualification)	B.Sc. (Civil) Engineer experience in Building Construction - Part Time	01		Technical Officer - NDT (Civil) or equivalent 5 years' experience in Building Construction - Full time	01	
	<b>Eligibility Requirements</b>	<b>Bidder's Qualification</b>											
	Category, Experience and Qualification	Required Nos.	Proposed by bidder (Name, experience and Qualification)										
	B.Sc. (Civil) Engineer experience in Building Construction - Part Time	01											
	Technical Officer - NDT (Civil) or equivalent 5 years' experience in Building Construction - Full time	01											
<i>(attach copies of certificates of academic qualification, experience, appointment letter or consent letter etc as annex VIII)</i>													
<b>Details of work plan and method</b>	<i>(attach as annex IX)</i>												
<b>Details of Credit Facilities requested as in the Bidding Data Cl. 4.4;</b>	Furnish relevant documents for Rs. 4.0 <b>million.</b> <i>(attach as annex X)</i>												
<b>Details of work in hand as in the Bidding Data Cl. 4.4(e)</b>	<i>(attach relevant document as annex XI)</i>												
<b>Working capital for the work in hand as in the Bidding Data Cl. 4.4(f)</b>	<i>(attach relevant document as annex XI)</i>												

.....  
Signature of the Bidder

Name:

Date:

Seal

**SECTION 5**  
**BIDDING DATA AND CONTRACT DATA**

## Bidding Data

### A. GENERAL

Instructions  
to Bidders  
Clause  
Reference  
1.1

The Employer is  
Name: **Vice Chancellor,  
Eastern University, Sri Lanka**  
Address: **Vanatharumoolai,  
Chenkalady**

The works consist of Demolishing, Excavation,  
Concreting, Masonry works, Plastering and  
painting ect..

SCOPE OF BID

1.2 Intended Completion Date is Ninety **calendar (90)  
Days** from the Start Date.

1.3 The office for collection of bid forms is  
Name: **Office of the Deputy Registrar  
Capital Works and Planning**

Address: **Eastern University, Sri Lanka  
Vantharumoolai, Chenkalady.**

The non-refundable fee is **Four Thousand  
(Rs. 4,000.00)**

The Bid forms will be issued **until 15:00 hrs** on 10.06.2026

2.1 The source of funds is **Consolidated Fund of  
Government of Sri Lanka**

SOURCE OF  
FUNDS

4.2 The registration required  
Specialty **Building Construction**

ELIGIBILITY  
AND  
QUALIFICATIO  
N OF THE  
BIDDER

Grade **ICTAD (CIDA) Grade C 07 or above**

Validity: valid **at the time of closing of the Bids** and  
also **at the time of award**

4.3 **Qualification Information**

The following Information shall be provided in Section 4

- ICTAD Registration;  
Registration Number  
Grade  
Specialty  
Expiry date
- VAT registration number
- Attach Construction Program
- Details of Company Registration/Incorporation  
of the Company/Business Registration for Sole  
Proprietor or Partnership
- Attach Documents (Power of Attorney or Board  
Resolution) authorizing the signatory of the Bid

to commit the Bidder.

- Total Turnover from construction work performed for each of the last five years which shall be confirmed by the Audited Financial statements as proof for item 4.4(a) below.
- Experience in works of a similar nature and size for each of the last five years as documentary proof for item 4.4(b) below.
- Construction Equipment.
- Qualification and experience of key Site Management, Project Management and Technical Personal proposed for the Contract as per 4.4(c) below.
- Attach Work plan and methods;
- Details of Credit Facilities as per 4.4 (d) below.
- Properly filling and signing of Non-Collusion Affidavit

#### 4.4 The Bidders Qualification Criteria:

- a) Average annual volume of construction work performed in any five years during last 10 years shall be at least Rupees **12.40 million**. (*Copies of Audited Financial Reports should be submitted along with the Bid*).
- b) Experience as a main contractor in Building construction or Construction of Boundary wall of one project similar nature and complexity costing not less than SLR. **6.20 million** over the last 10 years. (*Copies of the letter of acceptance and Completion Certificate shall be submitted along with the Bid.*)
- c) A Civil Engineer in part time and one Technical Officer with NDT (Civil) or equivalent with 05 years' experience (full time) should be assigned to the project an addition to the other technical staff needed by the bidder for satisfactory execution of the project.
- d) Minimum amount of liquid assets and /or credit facilities (after setting apart for other contractual commitments) and exclusive of any advance payments which may be made under this contract shall be not less than **SLR 4.0 million**. Credit facility should be addressed to Vice Chancellor, Eastern University, Sri Lanka and should be exclusively for this particular project
- e) Even though the bidders meet the above

qualifying criteria, they are subjected to be disqualified if they have misled or false statements in proof of the qualification requirements.

- f) Non-submission or partial submission of the documents listed above shall lead to rejection of the bid

<b>5.0</b>	<b>Add</b> Only who purchased the Bidding document be eligible to Bid	<b>ONE BID PER BIDDER</b>
<b>8.1</b>	<b>Delete and Add</b> The set of bidding documents comprises the documents listed below and addenda issued in accordance with Clause 10:  Invitation for Bids Volume 1 : Section 1   Instructions to Bidders Section 2   Standard Forms (Contract) Section 3   Conditions of Contract  Volume 2 : Section 4   Form of Bid, qualification Information and non-collusion affidavit Section 5   Bidding Data and Contract Data Section 6   Specification Section 7   Bill of Quantities Section 8   Drawings Section 9   Standard Form (Bid Security) Section 10  VAT Form Section 11  Check List  • Drawings in the Section 8 are available in the <b>Office of the Deputy Registrar/CW &amp; P, Eastern University, Sri Lanka</b> for reference.	<b>CONTENT OF BIDDING DOCUMENT</b>
<b>9.1</b>	Employer's address for the purpose of clarification is; Name: <b>Deputy Registrar/CW &amp; P, Phone: 0652240589</b> Fax: <b>0652240585</b>  Address: <b>Eastern University, Sri Lanka, Vantharumoolai, Chenkalady.</b>	<b>CLARIFICATION OF BIDDING DOCUMENTS</b>
<b>11.1</b>	The language of the bidding document shall be English	<b>LANGUAGE OF</b>

**12.1 Delete & Add**

The Bid submitted by the bidder shall comprise the following duly filled and completed in two copies marked "Original" and "Copy"

Invitation for Bids

Volume 1 :

- Section 1 Instructions to Bidders
- Section 2 Standard Forms (Contract)
- Section 3 Conditions of Contract

Volume 2 :

- Section 4 Form of Bid, qualification Information and non-collusion affidavit
- Section 5 Bidding Data and Contract Data
- Section 6 Specification
- Section 7 Bill of Quantities
- Section 8 Drawings
- Section 9 Standard Form (Bid Security)
- Section 10 VAT Form
- Section 11 Check list

**BID  
DOCUMENTS  
COMPRISING  
THE BID**

**13.3 Delete**

.....at the space provided in the B.O.Q." in accordance with the clause 47 of the Condition of Contract

**BID PRICES**

**13.4** The Contract is not subjected to price adjustment.

**15.1** The bid shall be valid up to **77 days** from the deadline for the submission of Bids.

**BID VALIDITY**

**16.1** Bid shall include a Bid Security using the forms included in Section 9.

**BID SECURITY**

**16.2** Bid Security shall be submitted by Bidder.

Bid Security shall be;

- Issued by an agency acceptable to Employer using the form for bid security (unconditional guarantee) included in Section 09 Standard Forms.
- In favour of **Vice Chancellor, Eastern University, Sri Lanka**
- for an amount **Rs. 150,000.00**
- Valid for a period up to **24.09.2026**

The agencies acceptable to Employer are:

- a commercial bank operating in Sri Lanka approved by the Central Bank of Sri Lanka;

	<ul style="list-style-type: none"> <li>• a bank based in another country but the guarantee “confirmed” by a bank operating in Sri Lanka approved by the Central Bank of Sri Lanka;</li> <li>• Construction Guarantee Fund.</li> </ul>	
<b>17.1</b>	<p><b>Pre bid meeting -</b>  <b>Venue: Board Room, Eastern University, Sri Lanka</b>  <b>Date 03.06.2026 Time: 10.00 am</b></p>	<b>PRE-BID MEETING</b>
	(a) The Employer’s address for the purpose of Bid submission is	<b>SEALING AND MARKING OF BIDS</b>
<b>19.2</b>	<p><b>The Chairman</b>  <b>Department Procurement Committee,</b>  <b>Eastern University, Sri Lanka,</b>  <b>Vantharumoolai, Chenkalady.</b></p> <p>(b) Contract Name: <b>Re-Construction of Boundary Wall Girls Hostel Area in Eastern University, Sri Lanka, Vantharumoolai.</b></p>	
<b>20.1</b>	The deadline for submission of bids shall be <b>at or before 10.30 am on or before 11.06.2026</b>	<b>DEADLINE FOR SUBMISSION OF BIDS</b>
<b>29.2(a)</b>	<p><b>Delete</b>  ... “but including Day works, where priced competitively</p>	<b>EVALUATION AND COMPARISON</b>
<b>31.1</b>	<p>After evaluation of Bids in accordance with the procedures described under Clauses 25, 26, 27, 28, 29 and 30 the Employer will inform to all the bidders in writing the selection of the successful bidder and the intention of contract award to such bidder. The unsuccessful bidders if they so wish, within 7 working days of such notice may make representation to the Department Procurement Appeal Committee (DPAC) at the address given below. Such representation shall be self - contained to enable the DPAC to arrive at a conclusion and a cash deposit to amount given below shall be made. The Employer may request the bidder who had made representation to submit further evidence during the investigation of such representation.</p> <p><b>Address: Chairman</b>  <b>Department Procurement Appeal Committee</b>  <b>Office of the Vice Chancellor</b>  <b>Eastern University, Sri Lanka</b>  <b>Vantharumoolai.</b>  <b>Chenkalady.</b></p> <p style="text-align: center;">Non - Refundable Cash deposit: Rs. 10,000.00</p>	<b>AWARD OF CONTRACT</b>
<b>31.2</b>	<p><b>Add to 31.2(C) as follows.</b>  If the past performance of a bidder is poor or unsatisfactory in terms of delay, bad workmanship or</p>	

any other, the bidder shall be subjected to disqualification.

**34.1** The amount of Performance Security is **five Percent (5%)** of the Initial Contract Price.

- Performance Security shall be issued by an agency acceptable to Employer using the form for Performance Security (unconditional guarantee) included in Section 02 Standard Forms and it shall be in favour of Vice Chancellor, Eastern University, Sri Lanka.

**PERFORMANCE  
SECURITY**

The agencies acceptable to Employer are:

- a commercial bank operating in Sri Lanka approved by Central Bank of Sri Lanka;
- a bank based in another country but the guarantee “confirmed” by a bank operating in Sri Lanka approved by Central Bank of Sri Lanka;
- Construction Guarantee Fund or

**Add**

**35.1** Advance Payment Security shall be issued by an agency acceptable to Employer using the form for Advance security (unconditional guarantee) included in Section 02 Standard Forms and it should be valid for 28 Days beyond the Intended Completion Date and shall be in favour of Vice Chancellor, Eastern University, Sri Lanka.

**ADVANCE  
PAYMENT**

The agencies acceptable to Employer are:

- a commercial bank operating in Sri Lanka approved by the Central Bank of Sri Lanka;
- a bank based in another country but the guarantee “confirmed” by a bank operating in Sri Lanka approved by the Central Bank of Sri Lanka
- Construction Guarantee Fund;

**36.0**

**Add**

- The Adjudicator shall be appointed by the CIDA.
- Fees and types of reimbursable expenses to be paid to the Adjudicator shall be on a case-to-case basis and shall be shared equally by the contractor and the Employer.

**ADJUDICATOR**

## Contract Data

*(Please note that the clause nos. given hereunder are that of Conditions of Contract)*

### A. GENERAL

<b>Clause No.</b>	The Employer is Name: <b>Vice Chancellor,</b> Address: <b>Eastern University, Sri Lanka</b>	<b>DEFINITIONS</b>
-------------------	---	--------------------

The Engineer is,  
Name: **Chief Engineer**  
Address: **Department of Building-EP, Batticaloa.**

Engineer Representative: **Executive Engineer**  
**Department of Building- EP, Batticaloa**

The works consist of Demolishing, Excavation, Concreting, Masonry works, Plastering and painting ect..

The Contract is fixed rate measure and pay basis.

The Site is located at Eastern University, **Vantharumoolai**

The Start Date shall be within **14** Days from the date of the Letter of Acceptance.

<b>2.3(10)</b>	The following documents also shall be a part of Contract. (i) VAT Form	<b>INTERPRETATION</b>
----------------	---	-----------------------

<b>8.1</b>	Schedule of other contractors: None	<b>OTHER CONTRACTORS</b>
------------	-------------------------------------	--------------------------

<b>9.1</b>	Schedule of Key Personnel:	<b>PERSONAL</b>
------------	----------------------------	-----------------

Category	Required Qualification and Working arrangement
Engineer	B.Sc. (Civil) Engineering experience in building construction - <b>Part Time</b>
Technical Officer	NDT (Civil) or equivalent with 05 years' experience in building construction - Full time

The minimum insurance covers shall be :

- 13.1**
- (a) The minimum cover for insurance of the Works and of Plant and Materials is **110%** of the Initial Contract Price. The maximum deductible for insurance of the Works and of Plant and Materials is **five percent (5.0%)** of Initial Contract Price.
  - (b) The minimum cover for loss or damage to Equipment is **hundred percent (100%)** of the Equipment cost. The maximum deductible for insurance of Equipment is **five percent (5%)** of the Equipment

	cost.	
	(c) The minimum cover for insurance of other property is <b>Rs.100,000/-</b>	
	(d) The minimum cover for personal injury or death, <ul style="list-style-type: none"> <li>• For third party and employees of the Employer and other persons engaged by the Employer in the work is <b>Rs.200,000/-</b> per event.</li> </ul>	
<b>13.2</b>	(a) The minimum cover for personal injury or death <ul style="list-style-type: none"> <li>• For the Contractor's workmen is <b>Rs.100,000/-</b> per event.</li> <li>• Contractor's Employees other than workmen is <b>Rs.150,000/-</b> per event.</li> </ul>	
<b>17.1</b>	The Intended Completion Date for the whole of works shall be <b>Ninety (90) Calendar Days</b> from the Start Date.	<b>INTENDED COMPLETION DATE</b>
<b>21.1</b>	The Site Possession Date shall be within <b>14 Calendar Days</b> from the date of the Letter of Acceptance.	<b>POSSESSION OF THE SITE</b>
<b>24</b>	<b>Add</b> The Adjudicator shall be appointed by CIDA	<b>DISPUTE RESOLUTION</b>
<b>27.1</b>	The Contractor shall submit a Programme for the Works within <b>14 Calendar Days</b> of delivery of the Letter of Acceptance	<b>PROGRAMME</b>
<b>27.3</b>	The period between Program update is <b>02 Months</b> .	
<b>27.4</b>	The amount to be withheld for late submission of a program is <b>two percent (2%) of the Contract Price</b> .  Action shall be taken to terminate the contract after withholding the said fine for <b>14 days</b> .	
<b>35.1</b>	The Defects Liability Period is <b>365 Days</b> .	<b>CORRECTION OF DEFECTS</b>
<b>39.2</b>	Engineer may order Net Variation within <b>7.5%</b> of the Contract Award Price with the approval of the Employer.	<b>VARIATIONS</b>
<b>40.2</b>	<b>Add at the end of the sub clause</b> <ul style="list-style-type: none"> <li>• In fixing the appropriate new rates, mark up for overheads and profits shall be limited to maximum of <b>16.0%</b> of the "Basic Cost" of such items. The Basic Cost means cost of materials, labour and equipment".</li> <li>• In fixing such 'Basic Cost', the Engineer shall use the rates for labour, which are used in preparing the "Building Schedule of Rates" and prices for Materials and Equipment shall be used the prevailing market prices and District Rates.</li> </ul>	<b>PAYMENTS OF VARIATIONS</b>
<b>44.1(m)</b>	Other Compensation Events: None	<b>COMPENSATION EVENTS</b>

46.1	Not Applicable	CURRENCIES
47.1	- deleted -	PRICE ADJUSTMENT
48.1	<p>The retention from each payment shall be <b>ten (10%) percent</b> of the certified work done.</p> <p>The limit of retention shall be <b>five (5%) percent</b> of the Initial Contract Price.</p>	RETENTION
49.	<p>The amount to be paid is 0.05% of Initial Contract Price per day.</p> <p>The maximum amount of liquidated damages for the whole of the Works shall be <b>ten (10%) percent</b> of the Initial Contract Price.</p>	LIQUIDATED DAMAGES
51.1	<p><b>Add</b></p> <ul style="list-style-type: none"> <li>• Advance Payment Security shall be issued by an agency acceptable to Employer using the form for Advance Security (unconditional guarantee) included in Section 02 Standard Forms and it should be valid for 28 Days beyond the Intended Completion Date and shall be in favour of Vice Chancellor, Eastern University, Sri Lanka.</li> </ul> <p>The agencies acceptable to Employer are:</p> <ul style="list-style-type: none"> <li>• A commercial bank operating in Sri Lanka approved by Central Bank of Sri Lanka;</li> <li>• a bank based in another country but the guarantee “confirmed” by a bank operating in Sri Lanka approved by Central Bank of Sri Lanka;</li> <li>• Construction Guarantee Fund;</li> </ul>	
52.1	<p>The Performance Security shall be <b>five (5.0%) percent</b> of Initial Contract Price.</p> <ul style="list-style-type: none"> <li>• Performance Security shall be issued by an agency acceptable to Employer using the form for Performance Security (unconditional guarantee) included in Section 02 Standard Forms and it shall be in favour of Vice Chancellor, Eastern University, Sri Lanka.</li> </ul> <p>The agencies acceptable to Employer are:</p> <ul style="list-style-type: none"> <li>• a commercial bank operating in Sri Lanka approved by Central Bank of Sri Lanka;</li> </ul>	SECURITIES

	<ul style="list-style-type: none"> <li>• a bank based in another country but the guarantee “confirmed” by a bank operating in Sri Lanka approved by Central Bank of Sri Lanka;</li> <li>• Construction Guarantee Fund;</li> </ul>	
<b>53</b>	<b>Deleted</b>	<b>DAY WORKS</b>
<b>58.1</b>	Schedule of operation and maintenance manuals: None. As Built Drawings: Contractor shall supply 03 copies of the same within 14 days from the issue of the practical completion certificate. (if applicable)	<b>OPERATION AND MAINTENANCE MANUALS</b>
<b>58.2</b>	The amount to be withheld for non submission of As Built Drawings is one (1%) percentage of the contract price	
<b>59.2</b>	<b><u>Add</u></b> <ol style="list-style-type: none"> <li>i. The Contractor does not employ the required Key Personal as stated in the Clause 9.1 of the Contract data, within 07 days after informing him to employ the Personnel.</li> <li>ii. The Contractor delays the submission of updated Programme by more than 14 days from the schedule date as stated in the Clause 27.3 in the Contract data.</li> <li>iii. Contractor’s performance is behind schedule and does not execute the works as per the approved work programme/amended work programme</li> </ol>	<b>TERMINATION</b>
<b>59.2(a)</b>	<b><u>Delete</u></b> .....28 Days..... <b>Add</b> .....14Days.....	
<b>60.1</b>	The percentage to apply to the value of the work not completed, representing the Employer’s additional cost for completing the Works, is <b>twenty-five (25%) percent</b> of the balance work.	<b>PAYMENT UPON TERMINATION</b>

**SECTION 6**  
**SPECIFICATIONS**

## GENERAL SPECIFICATIONS

- 01 Specifications for Building Works – Volume I  
ICTAD Publication No. SCA/4/I  
3<sup>rd</sup> Edition (Revised) – July 2004
  
- 02 Specifications for Building Works – Volume II  
ICTAD Publication No. SCA/4/II – Sanitary Installations  
2<sup>nd</sup> Edition (Revised) – October 2001
  
- 03 Specifications for Water Supply Sewerage and Storm Water Drainage Works  
ICTAD Publication No. SCA/3/2  
2<sup>nd</sup> Edition (Revised) – April 2002
  
- 04 Specifications for Electrical and Mechanical Works  
Associated with Building and Civil Engineering  
ICTAD Publication No. SCA/8  
2<sup>nd</sup> Edition (Revised) – August 2000

Copies of above publications shall be purchased from the Institute for Construction, Training and Development (ICTAD), "Sawsiripaya", 123, Wijerama Mawatha, Colombo 07.

**SECTION 7**  
**BILL OF QUANTITIES**

**Bill of Quantity for the Re-Construction of Boundary Wall Girls Hostel Area in Eastern University,  
Sri Lanka, Vantharumoolai.**

Item	Description	Unit	Qty	Rate	Amount
	<b><u>A - PRELIMINARY</u></b>				
A1	Provision for Bank change for performance bond.		Provisional Sum		20,000.00
A2	Provision for premium of Insurance of property, materials at site ,third party and Insurance against injury to workman.		Provisional Sum		50,000.00
A3	Allow for the water usage the construction work.	Item	Allow	Sum	
A4	Allow for the electrical usage the construction work.	Item	Allow	Sum	
A5	Providing Temporary shed for labours & materials	Item	Allow	Sum	
A6	Dewatering for construction as directed by engineer	Item	Allow	Sum	
	<b>Preliminary carried to summary</b>				
	<b><u>BOUNDARY WALL CONSTRUCTION</u></b>				
	<b><u>B- DEMOLISHER</u></b>				
B1	Allow for site clearing work and unwanted soil removing in existing damaged tree roots . and rate are including hire charges for earth work machineries (back-hoe loader / JCB /Excavator & tactor ) and cleared away as directed by engineer.	Item	Allow	Sum	
B2	Tree branches cutting & removing away from site as directed by engineer.	Item	Allow	Sum	
B3	Cutting down trees girth not exceeding 600mm, grubbing up roots & fill in excavation as directed by engineer.	Nos	2.00		
B4	Demolishing brick in cement foundation , walls and pillers stacked and debris cleared away from site as directed by engineer.	Cu.m	196.87		
	<b>Demolisher carried to summary</b>				
	<b><u>C- EXCAVATOR</u></b>				
	<b>Notes-</b>				
	N-1- Rate shall include for any working space as required by the contractor				
	N-2- Dewatering has not been measured Separately (Rate shall include for the cost of dewatering if necessary )				
	N-3 Rate shall include for levelling of trenches and keeping side plumb and back filling with selected excavated materials and				
C1	Excavation for wall foundation and column Footing in soft or loose soil , part return fill in and ram and surplus deposited within site as directed.	Cu.m	132.08		
C2	Supplying and laying polythene sheet for base before concreting	Sqm	142.40		
	<b>Excavator carried to summary</b>				
	<b><u>D - CONCRETE</u></b>				
	<b>Notes-</b>				
	N-1- All Concrete works shall Comply to the specification filled into form work and well packed around reinforcement.				
	N-2- Rate for concreting columns beams and slabs sahl include for kickers and coner slab				
	N-3- Rate for concreting shall include all necessay equipment which are required for concreting				
	Unless otherwise specified all concrete shall be 1:2:4(20) mix. mechanical concrete mixer shall be used one shall be made dense				

Item	Description	Unit	Qty	Rate	Amount
D1	75mm thick cement concrete 1:3:6 (38mm) in column footing .	Cu.m	3.92		
D2	150mm thick cement concrete 1:3:6 (38mm) in wall foundation .	Cu.m	13.66		
D3	Cement concrete 1:2:4 (20mm) in column footing . (R/F & shuttering paid separately) .	Cu.m	7.84		
D4	Cement concrete 1:2:4 (20mm) in column (R/F & shuttering paid separately) .	Cu.m	18.36		
D5	Cement concrete 1:2:4 (20mm) in plinth beam (R/F & shuttering paid separately) .	Cu.m	10.89		
D6	Cement concrete 1:2:4 (20mm) in lintol and beam. (R/F & shuttering paid separately)	Cu.m	6.76		
D7	Coping in 1:3 cement & sand , weathered and throated on top of wall 225mm x 100mm size complete with 12mm thick 1:3 color cement floating as directed by engineer	L.m	91.40		
D8	Concrete Coping in 1:2:4(20) , weathered and throated on top of 225mmx225mm size column, complete with 12mm thick 1:3 cement rendering.	No	93.00		
	<b>Concrete carried to summary</b>				
	<b><u>E - FORM WORK</u></b>				
	Notes-				
	N-1- All form work and shall be so constructed that no grout shall leak out 'curing concreting				
	N-2- All form work has been measured as the net contact surface measurement between concrete and formworks				
	All form work using Class II timber				
E1	Form work to shaft of columns footing.	Sqm	62.78		
E2	Form work to shaft of columns.	Sqm	263.66		
E3	Form work to plinth beam.	Sqm	60.02		
E4	Form work to lintol and beam.	Sqm	40.02		
E5	Form work to Coping	Sqm	77.35		
	<b>Form work carried to summary</b>				-
	<b><u>F - REINFORCEMENT WORK</u></b>				
	Notes-				
	N-1-All Reinforcement shall be free from mill scale , dirt , oil , paint , greases or loose dust before fixing in position and shall be brushed with stiff wire brush if so direct by the Engineer				
	N-2- Rebending of incorrectly bends are shall not be attempted				
	N-3- .The actual weight of steel at site will be calculated on the average weight of steel indicated in the mill certificate the same.				
	Reinforcement shall conform to including binding wire, cutting, bending, assembling, supplying and fabricating steel according to British standard practice and shown in structural drawing. All steel except 6mm to be tor steel manufacture by Sri Lanka steel.				
F1	R/F to Column,Plinth Lintol & Copping 10mm & 12mm tor Steel	kg	2419.95		
F2	R/F to Column , Lintol & Copping 6mm dia mild steel	kg	634.14		
	<b>Reinforcement carried to summary</b>				

Item	Description	Unit	Qty	Rate	Amount
	<b><u>G- MASONARY</u></b>				
G1	Random rubble masonry in 1:5 cement mortar in foundation.	Cu.m	109.95		
G2	100mm (4") thick cement block work in cement and sand mortar 1:5 in ground floor (size of each block 300 mmx200mmx100mm (12"x 8"x 4"))	Sqm	461.21		
	<b>Masonry carried to summary</b>				
	<b><u>H- PLASTERER</u></b>				
	The rates shall include for all temporary rules, screed and grounds etc. for raking out joints of new brick work or hacking new concrete for key. Internal and coved angles joints between different surfaces, arises quirks, intersection between curved				
H1	20mm thick Plinth plastering with 1:3 cement and sand mix with colour cement floating	Sqm	265.20		
H2	Plastering, 16mm thick cement and sand 1:5, to walls, finished smooth .	Sq.m	920.46		
H3	10mm thick plastering to R.C.C. column in cement & sand 1:3	Sq.m	100.44		
H4	16mm thick 1:3 cement plastering in narrow widths not exceeding 150mm wide & finished smooth.- Ground floor	l.m	892.80		
	<b>Plasterer carried to summary</b>				
	<b><u>K - PAINTER</u></b>				
	The rate shall include for all preparation of surface on clearing down smoothening knotting , stopping etc.protecting of floors and fitting removing and replacing doors and wibdows and fitting removing and replacing doors and windows furniture's and cleaning windows etc. upon complection.				
K1	Prepare and apply one coat of wall filler.	Sq.m	1,122.18		
K2	Prepare and apply two coats of whether shield emulsion to painting to external walls.	Sq.m	1033.78		
	<b>Painter carried to summary</b>				

Item	Description	Unit	Qty	Rate	Amount
------	-------------	------	-----	------	--------

S.No	SUMMARY				
1	<b>A - PRELIMINARY</b>				
2	<b>B- DEMOLISHER</b>				
3	<b>C- EXCAVATOR</b>				
4	<b>D - CONCRETE</b>				
5	<b>E - FORM WORK</b>				
6	<b>F - REINFORCEMENT WORK</b>				
7	<b>G- MASONARY</b>				
8	<b>H- PLASTERER</b>				
9	<b>K - PAINTER</b>				
	<b>Sub total - 01</b>				
	<b>Less: Provisional sum</b>				<b>70,000.00</b>
	<b>Sub Total - 02</b>				
	<b>Less: Discount For (If any)</b>				
	<b>Sub Total -03</b>				
	<b>Add: Provisional sum</b>				<b>70,000.00</b>
	<b>Sub Total - 04 (Carried to Fom of Bid)</b>				
	<b>Add: VAT 18%</b>				
	<b>Grand Total</b>				

Signature of the Bidder with seal:	
Name of the Bidder:	
Address of the Bidder:	
Date:	
Witness of the Signature:	
Name:.....	Signature:.....
Name: .....	Signature:.....

## **SECTION 08**

### **STANDARD FORM [BID SECURITY]**

## *Form of Bid Security*

*[this Guarantee form shall be filled in accordance with the instructions indicated in brackets]*

**Issuing Agency:** .....  
*[insert issuing agency's name and address of Issuing branch or Office]*

**Beneficiary:** Vice Chancellor,  
 Eastern University, Sri Lanka

**Date:** ..... *[insert (by issuing agency) date]*

**BID GURANTEE No:** ..... *[insert (by issuing agency) number]* We have been informed that ..... *[insert (by issuing agency) name of the Bidder]* (hereinafter called "the Bidder") has submitted to you its bid dated..... *[insert (by issuing agency) date]* (hereinafter called "the Bid") for the execution of ..... *[insert name of Contract]*

Furthermore, we understand that, according to the conditions, Bids must be supported by a Bid Guarantee.

At the request of the Bidder, we ..... *[insert name of issuing agency]* hereby irrevocably undertake to pay you any sum or sums not exceeding in total an amount of ..... *[insert amount in words]* ( ..... *[amount in figures]* upon receipt by us of your first demand in writing accompanied by a written statement stating that the Bidder is in breach of its obligation(s) under the bid conditions, because the Bidder:

- a) has withdrawn its Bid during the period of bid validity specified; or
- b) does not accept the correction of errors in accordance with the Instructions to Bidders(hereinafter "the ITB") ; or
- c) having been notified of the acceptance of its Bid by the Employer during the period of bid validity, (i) fails or refuses to execute the Contract Form, if required, or (ii) fails or refuse to furnish the Performance Security, in accordance with the ITB.

This guarantee will remain in force up to ..... *(insert date as at Invitation For Bid)*

Consequently, any demand for payment under this Guarantee must be received by us at the office on or before that date.

.....  
*[signature(s) of authorized representative(s)]*

# **SECTION - 9**

## **VAT FORM**

---

## Value Added Tax

**Service: Re-Construction of Boundary Wall Girls Hostel Area in Eastern University,  
Sri Lanka, Vantharumoolai.**

The bidder is required to show the total amount of V.A.T. for the bid, separately in the place shown below. The bidder is strictly **instructed not to include V.A.T. in his bid value.**

**Particulars to be furnished by the bidder :**

1. V.A.T. registration No of the bidder :	
2. V.A.T. amount for the bid :	

.....  
Signature of Bidder

Date : .....

**SECTION - 10**  
**Drawing**

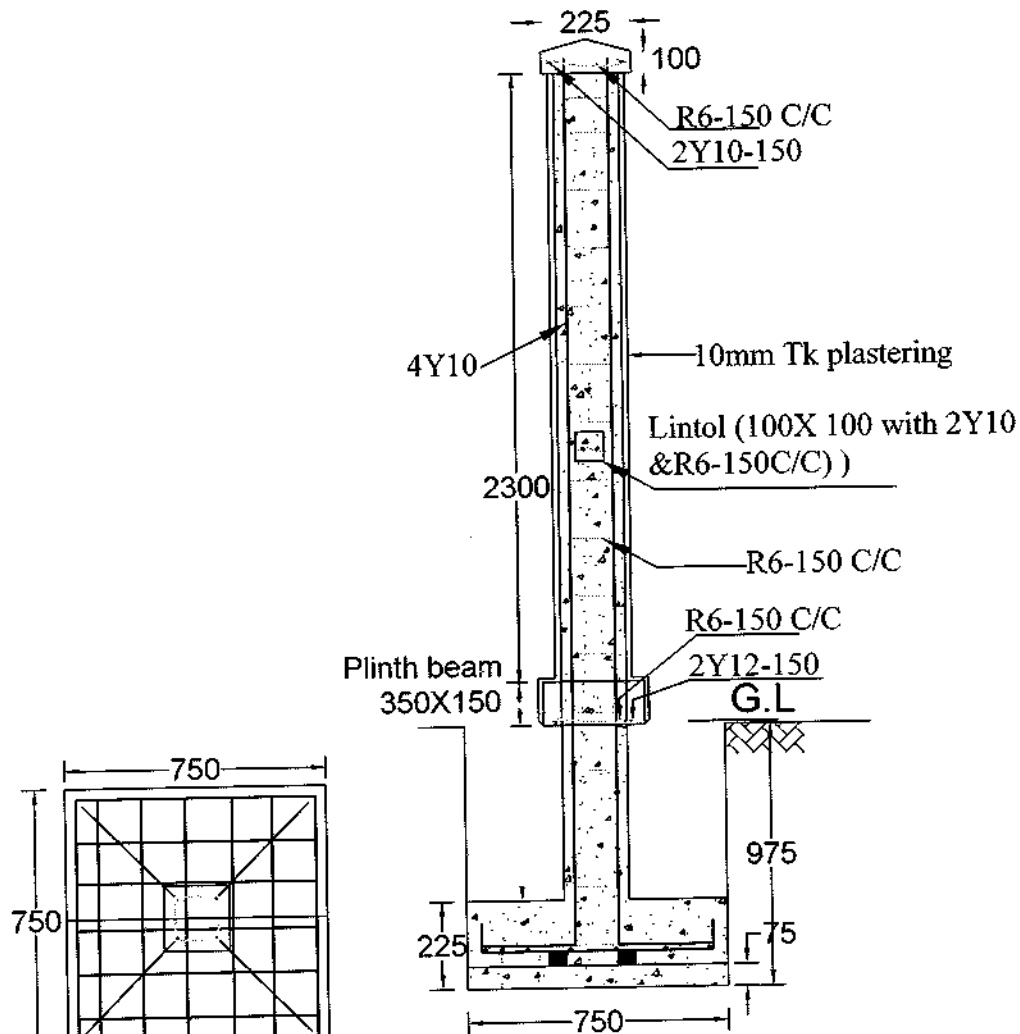

Detail of Column

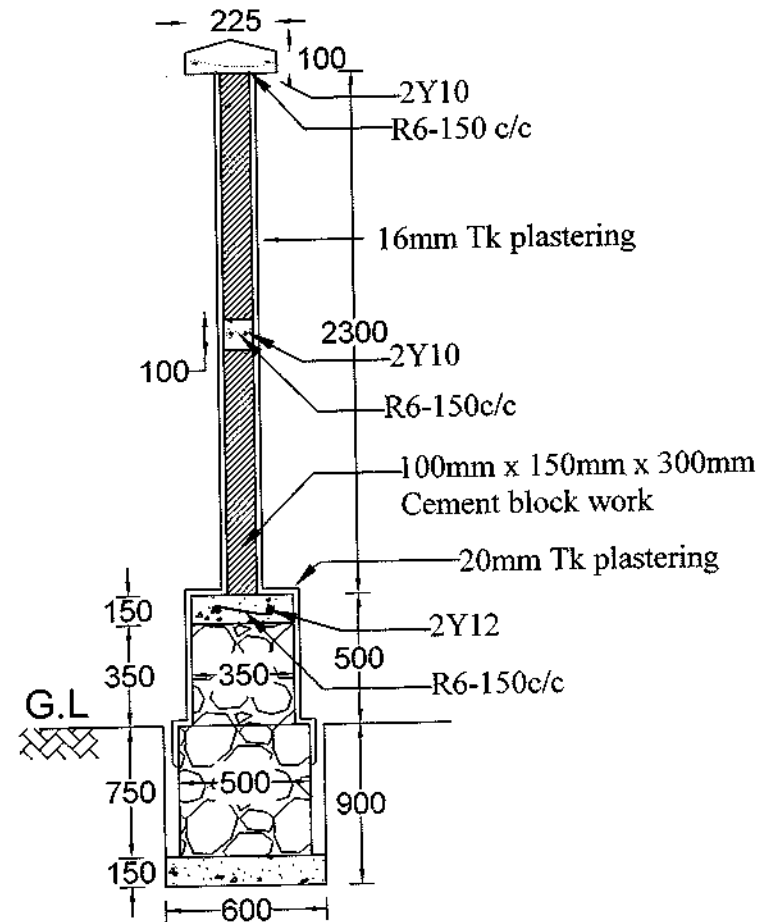
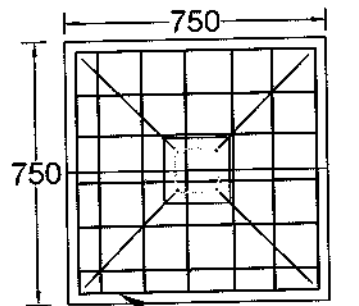

Detail of Parapet wall with Foundation

**Construction of boundary wall  
(Girls Hostel Area ) at university of  
Eastern, Vantharumoolai .**

CLIENTS APPROVED  
BY

EXECUTIVE ENGINEER

*S. Vin*  
Executive Eng.  
Dept. of Building  
Batticaloa.

**DEPARTMENT OF BUILDINGS  
BATTICALOA**

DRG NO:-

DATE

SCALE

1:25

CHECKED BY:-

DRAWN BY:-

MR.M.M.M.UWA 43

# **SECTION 11**

## **CHECK LIST**

**CHECK LIST***(The Bidder are advised to fill the following Table)*

	<b>ITEM</b>	<b>ITB CLAUSE</b>	<b>YES (TICK)</b>	<b>REFERENCE</b>
<b>1.</b>	<b>FORM OF BID</b>			
	Addressed to the Employer?	<b>18</b>		
	Completed?	<b>18</b>		
	Signed?	<b>18</b>		
<b>2.</b>	<b>BID SECURITY</b>			
	Addressed to the Employer?	<b>16</b>		
	Format as required?	<b>16</b>		
	Issuing Agency as specified?	<b>16</b>		
	Amount as requested?	<b>16</b>		
	Validity Period?			
<b>3.</b>	<b>ICTAD/CIDA Registration</b>			
	Grade?	<b>04</b>		
	Validity Period?	<b>04</b>		
<b>4.</b>	<b>QUALIFICATION INFORMATION</b>			
	All relevant information completed and submitted?	<b>04</b>		
	Signed?	<b>04</b>		
<b>5.</b>	<b>ADDENDUM</b>			
	Contents of the addendum (if any) taken in to account?	<b>10</b>		
<b>6.</b>	<b>BID PACKAGE</b>			
	All the documents given in Clause 12 .1 in the Bidding Data enclosed in the original and copy?	<b>12</b>		
	ITB Clause 19 followed before Sealing the Bid Package?	<b>19</b>		
<b>7</b>	<b>NON-COLLUSION AFFIDAVIT</b>	<b>12.1</b>		